

TZIDC-120

Electro-Pneumatic Positioner

Compact, well-proven, and flexible



For FOUNDATION Fieldbus

Compact and efficient

- With proven technology and intelligence

Communication-ready for FOUNDATION Fieldbus

- Fieldbus connection acc. to IEC 61158-2
- Power consumption 11.5 mA, 9 ... 32 V DC

Easy to commission, user-friendly

- Fully automatic autoadjust
- Setup via integrated operator panel or remote configuration
- Mechanical position indicator

EMV and CE conformity

Robust and environmentally ruggedized

- Shock and vibration influence < 1 %
- Aluminum housing, protection class IP 65

Additional temperature range

- -40 ... 85 °C (-40 ... 185 °F)

Mounting on pneumatic linear actuators or rotary actuators

Optional with pressure gauge block and filter regulator

Low operating cost

- Air consumption < 0.03 kg/h

ATEX, FM, CSA, GOST and IECEx approvals

Contents

1	Description	3
1.1	Pneumatics.....	3
1.2	Operation.....	3
1.3	Communication	3
1.4	Modular design.....	3
2	Mounting versions	5
2.1	To linear actuators in accordance with the standard	5
2.2	To rotary actuators in accordance with the standard	5
2.3	Integral mounting to control valves	5
2.4	Special actuator-specific mounting	5
3	Operation	7
3.1	General.....	7
3.2	Operator panel	8
4	Communication	9
4.1	General.....	9
4.2	Configuration	9
4.3	FOUNDATION Fieldbus H1	9
4.4	Benefits of FF communication.....	9
4.5	FF communication for TZIDC-120.....	9
5	Specifications	10
5.1	Communication	10
5.2	Designation	10
5.3	Output.....	10
5.4	Travel.....	10
5.5	Air supply.....	10
5.6	Transmission data and influences.....	11
5.7	Environmental capabilities	11
5.8	Housing	11
5.9	Options	12
5.10	Accessories	12
6	Ex relevant specifications	13
6.1	ATEX	13
6.2	IECEX	14
6.3	FM/CSA.....	15
7	Electrical connections	19
8	Dimensions	21
9	Ordering information	24
9.1	Accessories	26

1 Description

The TZIDC-120 is an electronically configurable positioner with communication capabilities designed for mounting to pneumatic linear or rotary actuators. It features a small and compact design, a modular construction, and an excellent cost-performance ratio.

Fully automatic determination of the control parameters and adaptation to the final control element yield considerable time savings and an optimal control behavior.

1.1 Pneumatics

An I/P module with subsequent pneumatic amplifier is used to control the pneumatic actuator. The well-proven I/P module proportionally converts the permanent electrical positioning signal from the CPU into a pneumatic signal used to adjust a 3/3-way valve.

The air flow for pressurizing or depressurizing the actuator is continuously adjusted. As a result, excellent control is achieved. When reaching the set point, the 3/3-way valve is closed in center position to minimize the air consumption.

Four different pneumatics versions are available: for single-acting or double-acting actuators, each with "fail-safe" or "fail-freeze" function.

1.1.1 "Fail-safe" function

If the electrical power supply fails, the positioner output 1 is depressurized, and the pneumatic actuator's return spring moves the valve to the defined safe position. In case of a double-acting actuator the second output 2 is additionally pressurized.

1.1.2 "Fail-freeze" function

If the electrical power supply should fail, the positioner output 1 (and 2, if applicable) is closed and the pneumatic actuator stops ("freezes") the valve in the current position. If compressed air supply should fail, the positioner depressurizes the actuator.

1.2 Operation

The positioner has a built-in operating panel providing a 2-line LCD and 4 pushbuttons for optimal local configuration, commissioning and operational monitoring.

Alternatively, the appropriate configuration program and the available communication option can be used.

1.3 Communication

Communication with the TZIDC-120 positioner occurs via FOUNDATION Fieldbus.

1.4 Modular design

The TZIDC-120 basic model can be enhanced at any time by retrofitting optional equipment. Option modules for analog or digital position feedback can be installed. Additionally, a mechanical position indicator, proximity switches or 24 V microswitches are available for indicating the position independently of the mother board function.

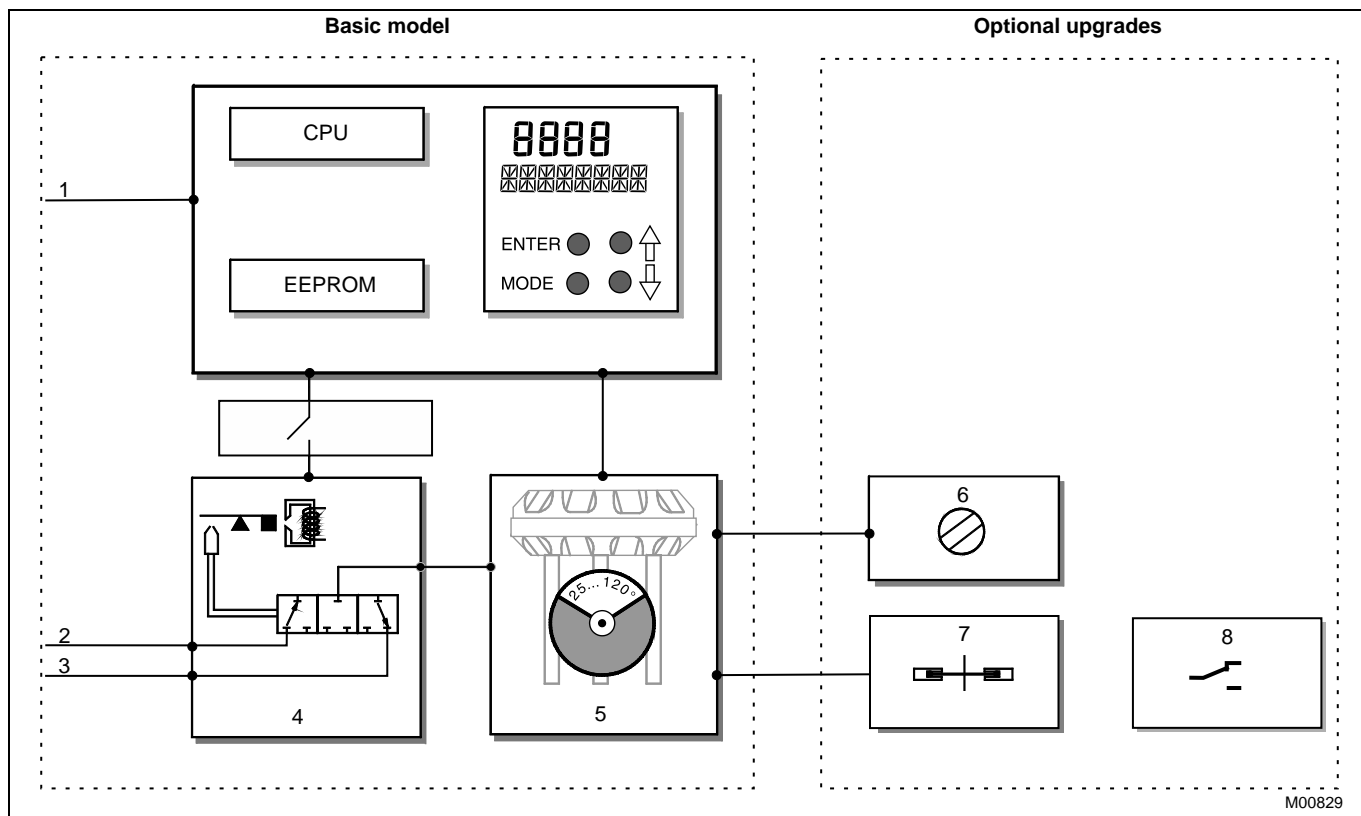

Fig. 1: TZIDC-120 schematic diagram

Basic model

- 1 Bus connector
- 2 Supply, 1.4 ... 6 bar
- 3 Exhaust
- 4 I/P module with 3/3-way valve
- 5 Position sensor (optional up to 270° rotation angle)

Optional upgrades

- 6 Mechanical position indicator
- 7 Mechanical feedback with proximity switches
- 8 Mechanical feedback with microswitches 24 V



Important

With optional upgrades either the “mechanical feedback with proximity switches” (7) or the “mechanical feedback with microswitches 24 V” (8) can be used.

In both cases, the “mechanical position indicator” (6) must be installed.

2 Mounting versions

2.1 To linear actuators in accordance with the standard

Lateral attachment is in accordance with DIN / IEC 534 (lateral attachment to NAMUR). The required attachment kit is a complete set of attachment material, but does not include the screwed pipe connections and air pipes.

2.2 To rotary actuators in accordance with the standard

This attachment is designed for mounting according to the standard VDI / VDE 3845. The attachment kit consists of a console with mounting screws for mounting on a rotary actuator. The adapter for coupling the positioner feedback shaft to the actuator shaft has to be ordered separately. Screwed pipe connections and air pipes have to be provided on site.

2.3 Integral mounting to control valves

The TZIDC-120 positioner featuring standard pneumatic action is available as an option for integral mounting.

The required holes are found at the back of the device.

The benefit of this design is that the point for mechanical stroke measurement is protected and that the positioner and actuator are linked internally. No external tubing is required.

2.4 Special actuator-specific mounting

In addition to the mounting methods described above, there are special actuator-specific attachments.

Please contact us for details.

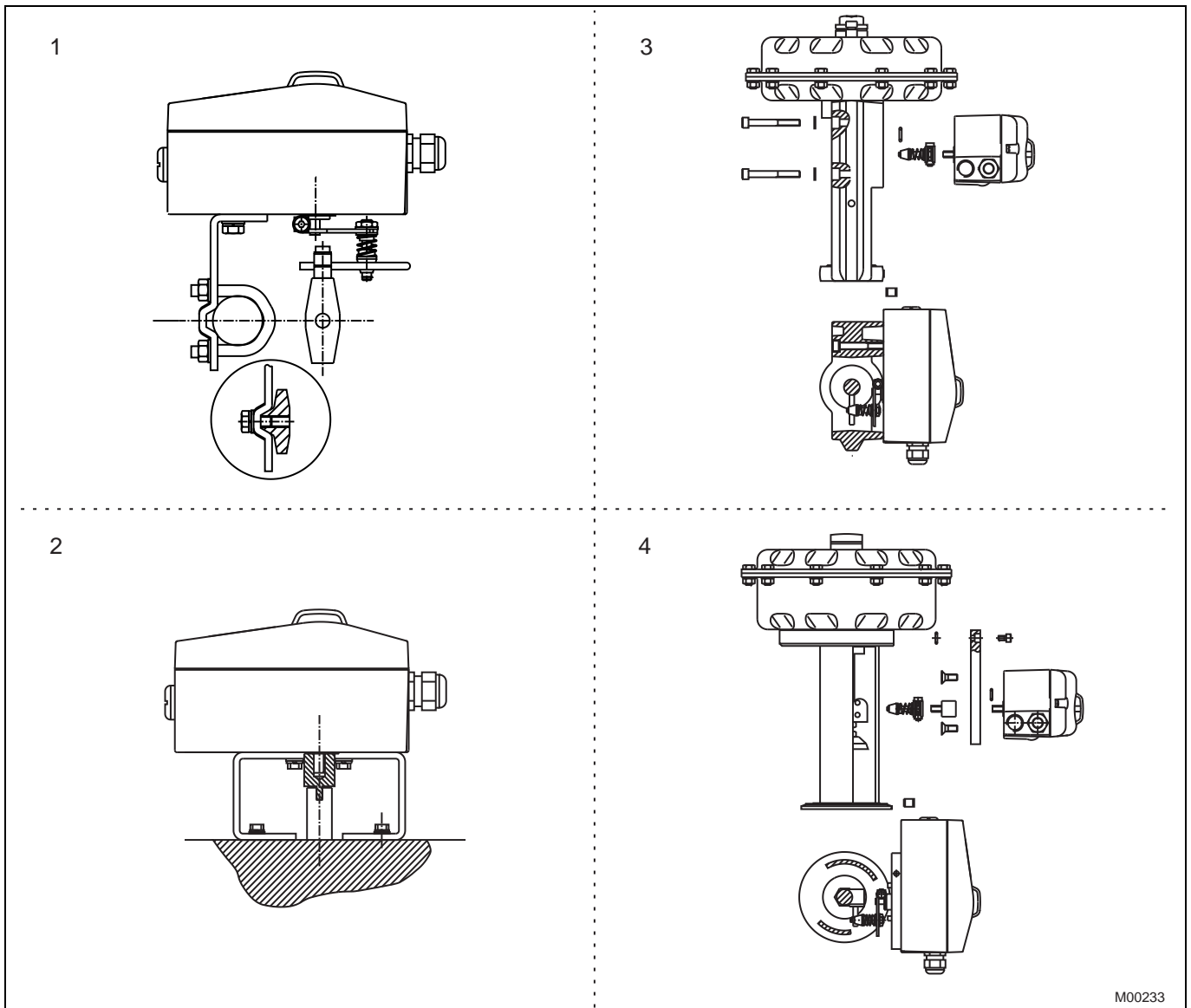

M00233

Fig. 2: Mounting options

- 1 Mounting to linear actuators acc. to DIN / IEC 534
- 2 Mounting to rotary actuators to VDI / VDE 3845

- 3 Integral mounting to control valves
- 4 Integral mounting to control valves by using an adapter panel

3 Operation

3.1 General

The intelligent, microprocessor-controlled TZIDC-120 positioner allows you to obtain optimal results. The positioner features high-precision control functions and high operational reliability. The optimal parameters are set automatically during autoadjust. If necessary, corrections can be made manually.

The total range of parameters includes:

- Operating parameters
- Adjustment parameters
- Monitoring parameters

3.1.1 Operating parameters

The following operating parameters can be activated and configured:

Characteristic curve (travel = f {signal})

Linear, equal percentage 1:25 or 1:50 or 25:1 or 50:1 or freely configurable with 20 reference points.

Tolerance band

When the tolerance band is reached, the position is considered as corrected. From this point on, the position is further slowly re-adjusted until the dead band is reached. The factory setting for this parameter is 0.3 %.

Dead band (sensitivity)

When reaching the dead band, the position is held. The factory setting for this parameter is 0,1 %. The tolerance band and dead zone are automatically calculated as part of the controller's self-optimization process.

Travel limit

The positioning travel, i.e. the stroke or angle of rotation, can be reduced as required within the full range of 0 ... 100 %, provided that a minimum value of 20 % is observed.

Shut-off function

This function can be selected separately for each end position. When the respective configured limit value is exceeded, the shut-off function causes the actuator to travel immediately to the selected end position.

Travel time prolongation

This function can be used to increase the max. travel time for full travel. This time parameter can be set separately for each direction.

Important
This function can only be used with the pneumatics with the safety function "fail-safe".

Rules in end position

For both end positions, you can select whether the pneumatic actuator is vented fully or whether the position is controlled.

3.1.2 Adjustment parameters

The TZIDC-120 positioner has a special function for automatic adjustment of the parameters. The function is launched either via the integrated operator's panel or the user interface.

The following adjustment parameters can be activated and configured:

Parameters for control block

To optimally adjust the actuator position, the control parameters can be set individually for the control behavior of the valve.

Range 0 ... 100 %

Configuration of end positions for the valve to be adjusted to start position "0" and end position "100 %".

Direction of the actuator

Calibration to both possible directions of action:

Air opens / spring force closes

or

Air closes / spring force opens

Display 0 ... 100 %

Adjusting the display (0 ... 100 %) to the direction of action for opening or closing the valve.

3.1.3 Monitoring parameters

Various functions for permanent operational monitoring are implemented in the TZIDC-120 operating program, e.g.:

- Internal positioning time-out
- Sensor monitoring
- Backup monitoring

While automatic commissioning is in progress, the current state is continuously indicated on the integrated LCD. Remaining messages can be retrieved via the user interface.

The fieldbus enables users to implement enhanced monitoring in the control system. A special window displays the most important process variables ONLINE such as the positioning signal (in %), the position (in %), the control deviation (in %) as well as the status messages.

3.2 Operator panel

The TZIDC-120 positioner's operator panel with four pushbuttons allows for

- operational monitoring
- manual control
- configuration
- fully automatic commissioning

The operator panel is protected by a cover which avoids unauthorized access to the operating elements.

3.2.1 Single-button commissioning

Commissioning the TZIDC-120 positioner is especially easy. The standard Autoadjust function for automatic adaptation of the device parameters can be started by simply pressing a single front panel button, and without knowing parameterization details.

Depending on the selected actuator type (linear or rotary), the displayed zero position is automatically adapted:

- for linear actuators counter-clockwise (CTCLOCKW)
- for rotary actuators clockwise (CLOCKW).

Besides this standard function, a customized "Autoadjust" function is available. The function is launched either via the operator's panel or the configuration program.

3.2.2 Operation

The four pushbuttons enable users to select operating levels, configure the device and store settings. In addition to the known operating functions, a simplified autoadjust can be performed. This enables you to launch the device's automatic configuration function in a few steps and without detailed knowledge regarding parameters.

When changing the actuator type from linear to rotary, the zero position of the display is automatically updated. This is indicated in the display for valves closing on the right in the closed position 0 %.

3.2.3 Display

The information indicated by the 2-line LCD is permanently updated and adapted during operation, to inform the operator in an optimal way.

During control operation the following TZIDC-120 data can be called up by pressing the pushbuttons briefly:

Up button	Cyclic communication:
	- Setpoint (%)
	- Setpoint status
	Acyclic communication:
	- Status of communication
Down button	Operating mode on the bus and bus address
Enter	Software Version



Fig. 3: TZIDC-120 with removed cover, view of the operator panel

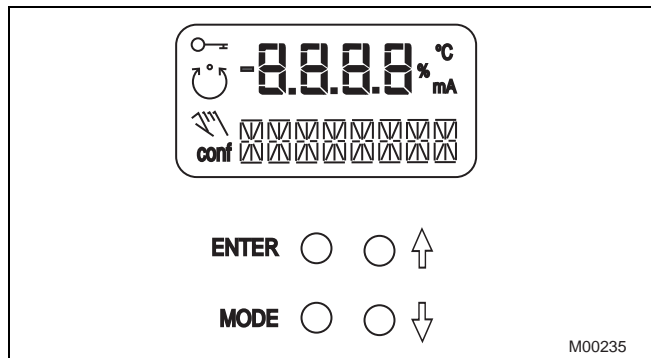

Fig. 4: TZIDC-120 operating elements and display

4 Communication

4.1 General

Communication occurs via the fieldbus connection. In conformance with bus convention, device data is read in cyclic operation (operating mode AUT, MAN or RCAS) and data is written in the O/S (out-of-service) mode. Newly set parameters are saved in the non-volatile memory directly after writing to the field device, and become active immediately.

FOUNDATION Fieldbus is an open bus standard that enables users to integrate devices from various manufacturers in a system and supports interoperability.

Communication occurs via an FF system using the fast, superordinate HSE bus (high-speed ethernet) and the slower but intrinsically safe H1 bus. It is layer-oriented and based on the ISO/OSI model (International Standards Organization's Open System Interconnect).

A device description (DD) provided in file format by the manufacturer contains all the necessary information on the FF device and its functions.

4.2 Configuration

The user interface for the TZIDC-120 positioner is integrated in the control system. This allows you to work with the fieldbus in the commissioning phase, during operation and for service tasks when monitoring the device, setting parameters and uploading data.

4.3 FOUNDATION Fieldbus H1

The FOUNDATION Fieldbus H1 was developed primarily for use in process automation. The transmission method (physical layer) complies with IEC 61158. The power supply for the field devices is provided concurrent with signal transmission via the fieldbus line. FOUNDATION Fieldbus H1 is also well suited for use in explosion-proof installations.

4.4 Benefits of FF communication

- Standardized function blocks and an interoperability test ensure smooth integration of devices from various manufacturers
- Acyclic access to device data (even during operation) for configuration, diagnostics and service
- High system uptimes based on comprehensive device and bus diagnostics as well as default value strategies in the event of an error
- Support for efficient facility management through provision of operating values

4.5 FF communication for TZIDC-120

Using the FOUNDATION Fieldbus in combination with a suitable configuration program installed in the control system, the TZIDC-120 can be easily monitored, configured and queried. Newly set parameters are saved in the non-volatile memory directly upon download to the device, and become active immediately.

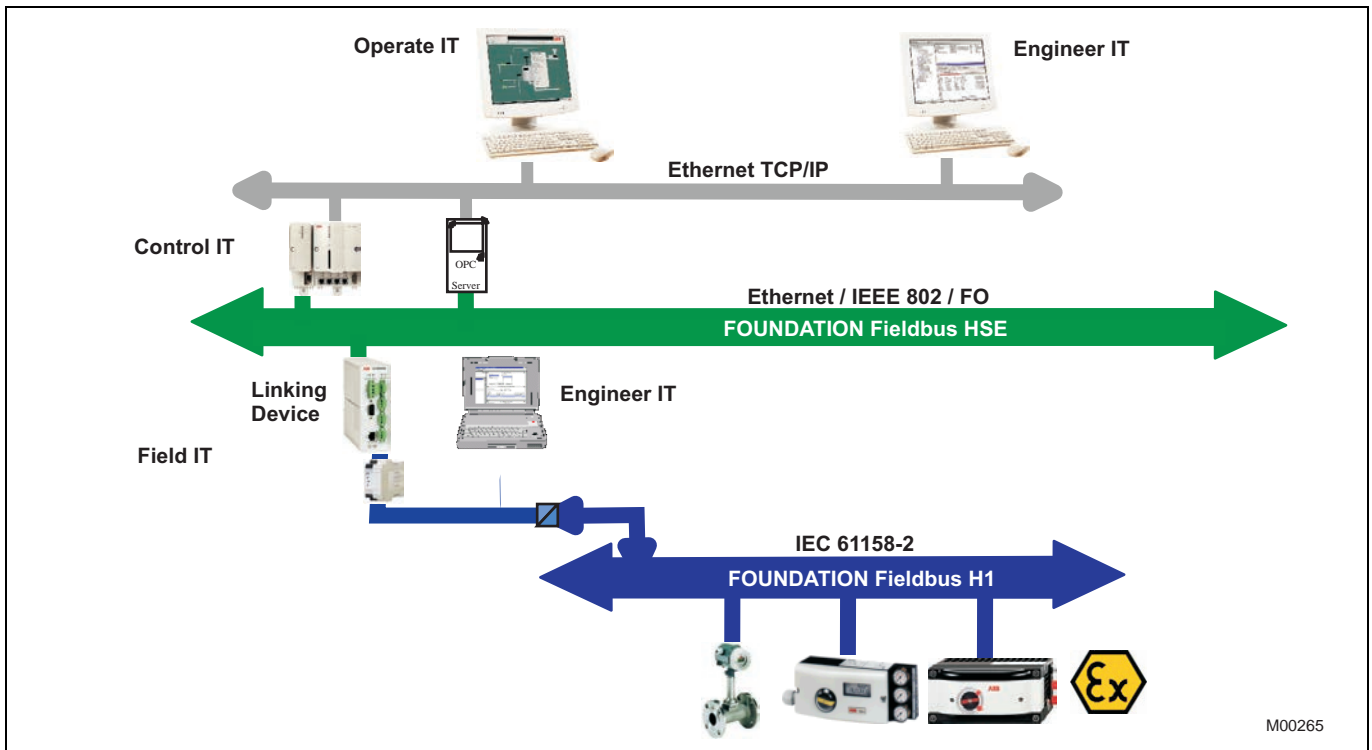

Fig. 5: Communication via FOUNDATION Fieldbus

5 Specifications

5.1 Communication

Specification	FOUNDATION fieldbus, version 1.5
Physical Layer	Model 113, 121 (IEC 61158-2)
Transmission rate	31.25 Kbit/s
Block types	1 AO Function block 1 PID block 1 Resource block 1 Transducer block 1 physical block
Block class	AO block: standard PID block: enhanced Resource block: enhanced Transducer block: custom
Number of linkage objects	22
Device description (DD)	Rev. No. 1 (file name 0201.ffo, 0201.sym)
File	Common file format (file name: 020101.cff)
Max. execution time	AO block: 40 milliseconds PID block: 50 milliseconds
Supply voltage	Power feed from the fieldbus 9.0 ... c 32.0 V DC
Max. permissible voltage	35 V DC
Power consumption	11.5 mA
Current in the event of an error	15 mA (11.5 mA + 3.5 mA)
FF Certification	Registered with ITK 4.51, Dec.2003 IT Camp. Number IT023200
Device name	ABB TZIDC-120-TAG
Dev. ID	0003200028-TZIDC-120XXXXXXXXXX
Device address	Between 10 and 247, default address 23
ATEX certificate for FISCO	Yes
Insensitive to reversed polarity	Yes
Class	LM profile 32L, 31 PS
Factory default	The positioner is not delivered in an aligned state. To adjust the operating range and control parameters, an automatic configuration must be run on the unit. Otherwise, the transducer block remains in out-of-service mode.
Diagnostic functions	Self-diagnostics for the positioner hardware and software, valve diagnostics with enhanced alarm handling

5.2 Designation

Device name	ABB TZID-C120-TAG
Dev. ID	0003200028-TZID-C120XXXXXXXXXX

5.3 Output

Range	0 ... 6 bar (0 ... 90 psi)
Air capacity at 1.4 bar (20 psi) supply pressure	5.0 kg/h = 3.9 Nm ³ /h = 2.3 scfm
at 6 bar (90 psi) supply pressure	13 kg/h = 10 Nm ³ /h = 6.0 scfm
Output function	For single or double-acting actuators, air is vented from actuator or actuator is blocked in case of (electrical) power failure
Shut-off values	End Position 0 % = 0 ... 45 % End position 100 % = 55 ... 100 %

5.4 Travel

Rotation angle Used range	25 ... 120°	rotary actuators, optionally 270°
	25 ... 60°	linear actuators
Travel time prolongation Setting range	0 ... 200 seconds, separately for each direction	

5.5 Air supply

Instrument air	free of oil, water and dust to DIN/ISO 8573-1. Pollution and oil content according to Class 3 (purity: max. particle size = 5 µm, max. particle density = 5 mg / m ³ ; oil content: max. concentration = 1 mg / m ³ ; pressure dew point: 10 K below operating temperature)
Supply pressure	1.4 ... 6 bar (20 ... 90 psi)

i IMPORTANT (NOTE)

Do not exceed the maximum operating pressure of the actuator!

Air consumption	< 0.03 kg/h / 0.015 scfm (independent of supply pressure)
------------------------	---

5.6 Transmission data and influences

Direction of action (output signal or pressure in actuator)

Increasing	Increasing output signal 0 ... 100 % Increasing pressure y1 in the actuator
Decreasing	Increasing output signal 0 ... 100 % Decreasing pressure y1 in the actuator

Characteristic deviation	< 0.5 %
Tolerance band	0.3 ... 10 %, adjustable
Dead band	0.1 ... 5 %, adjustable
Resolution (A/D conversion)	> 16000 steps
Sample rate	20 ms
Influence of ambient temperature	< 0.5 % for each 10 K
Influence of vibration	≤ ± 1 % to 10 g and 80 Hz

Seismic requirements

Meets requirements of DIN / IEC 68-3-3 Class III for strong and strongest earthquakes.

Influence of mounting orientation

Not measurable.

Meets the requirements of the following directives

- EMC Directive 2004/108/EC as of December 2004
- EC Directive for CE conformity marking

5.7 Environmental capabilities

Ambient temperature

For operation, storage and transport: -40 ... 85 °C (-40 ... 185 °F)

Relative humidity

Operational (with closed housing and air supply switched on):	95 % (annual average), condensation permissible
Transport and storage:	75 % (annual average), non-condensing

5.8 Housing

Material / Degree of protection

Aluminum with ≤ 0.1 % copper, protection class IP 65 (optional IP 66) / NEMA 4X

Surface / Color

Electrostatic dipping varnish with epoxy resin, stove-hardened. Case varnished black, RAL 9005, matte, housing cover Pantone 420.

Electrical connections

Screw terminals: Max. 1.0 mm² (AWG 17) for options
Max. 2.5 mm² (14 AWG) for bus connector



IMPORTANT (NOTE)

Do not expose the terminals to strain.

Four thread combinations for cable entry and pneumatic connection

- Cable: thread 1/2-14NPT, air pipe: thread 1/4-18 NPT
 - Cable: thread M20 x 1,5, air pipe: thread 1/4-18 NPT
 - Cable: thread M20 x 1,5, air pipe: thread G 1/4
 - Cable: thread G 1/2, air pipe: thread Rc 1/4
- (Optional: With cable gland(s) and pipe plugs if necessary)

Weight

1,7 kg (3,75 lb)

Mounting orientation

Any

5.9 Option

Mechanical position indicator

- Indicator disk
- Cover with transparent dome
- Symbol label
- Extension shaft

Digital position feedback with proximity switches

Two proximity switches for independent position signaling. Switching points adjustable between 0 ... 100 %

Current circuits acc. to DIN 19234 / NAMUR

Supply voltage 5 ... 11 V DC

Signal current < 1.2 mA Switching state logical "0"

Signal current > 2.1 mA Switching state logical "1"

(function dependent on software and electronics for actuator)

Direction of action (logical state)

Proximity switch	Position			
	< Lim. 1	> Lim. 1	< Lim. 2	> Lim. 2
SJ2-SN (NC)	0	1	1	0

Digital position feedback with 24 V microswitches*

Two microswitches for independent position signaling. Switching points adjustable between 0 ... 100 %.

Voltage max. 24 V AC / DC

Load rating max. 2 A

Contact surface 10 µm Gold (AU)

Mechanical position indicator

Indicator disk in enclosure cover, linked with positioner feedback shaft.

* The "digital feedback" is activated directly from the axis of rotation for the variable pick-off and can only be used with the "mechanical position indicator".

i IMPORTANT (NOTE)

These options are also available for retrofitting by Service.

5.10 Accessories

Mounting material

- Attachment kit for linear actuators to DIN / IEC 534 / NAMUR
- Attachment kit for part-turn actuators to VDI / VDE 3845
- Attachment kit for integral mounting to control valves
- Attachment kit for actuator-specific attachment upon request

Pressure gauge block

- Pressure gauges for supply and output pressure
- Pressure gauges with housing ø 28 mm
- Aluminum connection block in black
- Installation material for mounting on positioner

Filter regulator

All metal version in brass, varnished black, bronze filter element (40 µm) and condensate drain.

Max. pre-pressure 16 bar (232 psi), output adjustable to 1.4 ... 6 bar (20 ... 90 psi)

6 Ex relevant specifications

6.1 ATEX

6.1.1 ATEX Ex i

Marking:	II 2 G Ex ia IIC T6 resp. T4 Gb II 3 G Ex ic IIC T6 resp. T4 Gc
Type examination certificate:	TÜV 02 ATEX 1834 X
Type:	Intrinsically safe equipment
Standards:	EN 60079-0:2009 EN 60079-11:2007 EN 60079-27:2008

Temperature class	Ambient temperature range
T4	-40 ... 85 °C
T5	-40 ... 55 °C
T6	-40 ... 40 °C

Electrical data for ia/ib/ic for groups IIB/IIC

With the intrinsically safe Ex i IIC type of protection, only for connection to a certified FISCO power supply unit, a barrier or a power supply unit with linear characteristic curves and the following maximum values:

Signal circuit (terminal +11 / -12 or + / -)	U _i = 24 V I _i = 250 mA P _i = 1.2 W Characteristic curve: linear L _i < 10 µH C _i < 5 nF
---	---

With the intrinsically safe Ex ia IIC or Ex ib IIC type of protection, only for connection to a certified intrinsically safe circuit with maximum values:

Mechanical digital feedback (terminal Limit1 +51 / -52 or Limit2 +41 / -42)	For maximum values, see EC type examination certificate number PTB 00 ATEX 2049 X
---	---

6.1.2 ATEX Ex n

Marking:	II 3 G Ex nA IIC T6 resp. T4 Gc
Declaration of conformity:	TÜV 02 ATEX 1943 X
Type:	"n" type of protection
Device group:	II 3 G
Standards:	EN 60079-15:2010 EN 60079-0:2009

II 3 G Temperature class	Ta Ambient temperature range
T4	-40 ... 85 °C
T6	-40 ... 50 °C

Electrical data for II 3 G Ex nA IIC T6 or T4 Gc

Signal circuit (terminal +11 / -12)	U = 9 ... 32 V DC I = 11.5 mA
Mechanical digital feedback (terminal Limit1 +51 / -52 or Limit2 +41 / -42)	U = 5 ... 11 V DC

Special requirements

- Devices may only be connected to circuits in zone 2 if they are suitable for operation in zone 2 potentially explosive atmospheres and for the conditions prevailing at the installation location (manufacturer's declaration or certificate from an inspection authority)
- For the "digital feedback with proximity switches" circuit, external measures must be implemented to prevent the rated voltage from being exceeded by more than 40 % in the event of transient disturbances
- It is only permissible to connect, disconnect and switch live circuits during installation or maintenance, or for the purpose of carrying out repairs. Note: It is considered very unlikely that a potentially explosive atmosphere would be present in zone 2 at the same time that installation or maintenance/repair work was being carried out
- Only non-flammable gases may be used for the pneumatic power supply
- Only use suitable cable entries that meet the requirements of IEC 60079-15

6.2 IECEX

6.2.1 IECEX

Marking:	Ex ia IIC T6 or T4 Gb Ex ib IIC T6 or T4 Gb Ex ic IIC T6 or T4 Gc Ex nA IIC T6 or T4 Gc
Certificate no.:	IECEX TUN 04.0015X
Issue no.:	5
Type:	Intrinsic safety "i" or type of protection "n"
Standards:	IEC 60079-0:2011 IEC 60079-11:2011 IEC 60079-15:2010

Type and marking	TZIDC-120 Ex i IIC	TZIDC-120 Ex nA IIC
Temperature class	Ambient temperature range	
T4	-40 ... 85 °C	-40 ... 85 °C
T6	-40 ... 40 °C	-40 ... 50 °C

6.2.2 IECEX i

Electrical data for TZIDC-110 for ia/ib/ic with "Ex i IIC T6" or "T4 Gb" marking

With the intrinsically safe Ex i IIC type of protection, only for connection to a certified FISCO power supply unit, a barrier or a power supply unit with linear characteristic curves and the following maximum values:

Signal circuit (terminal +11 / -12 or + / -)	U _i = 24 V I _i = 250 mA P _i = 1.2 W Characteristic curve: linear
---	--

6.2.3 IECEX n

Electrical data for TZIDC-120 with "Ex nA IIC T6" or "T4 Gc" marking	
Signal circuit (terminal +11 / -12)	U = 9 ... 32 V DC I = 11.5 mA
Mechanical digital feedback (terminal Limit1 +51 / -52 or Limit2 +41 / -42)	U = 5 ... 11 V DC

Special requirements

- Devices may only be connected to circuits in zone 2 if they are suitable for operation in zone 2 potentially explosive atmospheres and for the conditions prevailing at the installation location (manufacturer's declaration or certificate from an inspection authority)
- For the "digital feedback with proximity switches" circuit, external measures must be implemented to prevent the rated voltage from being exceeded by more than 40 % in the event of transient disturbances.
- It is only permissible to connect, disconnect and switch live circuits during installation or maintenance, or for the purpose of carrying out repairs. Note: It is considered very unlikely that a potentially explosive atmosphere would be present in zone 2 at the same time that installation or maintenance/repair work was being carried out
- Only non-flammable gases may be used for the pneumatic power supply
- Only use suitable cable entries that meet the requirements of IEC 60079-15

6.3 FM/CSA

6.3.1 CSA Certification Record

Certificate: 1649904 (LR 20312)
Class 2258 04 PROCESS CONTROL
EQUIPMENT – Intrinsically Safe,
Entity – For Hazardous Locations

Class I, Div 1, Groups A, B, C and D;
Class II, Div 1, Groups E, F, and G,
Class III, Div 1, Enclosure Type 4X:

Model TZIDC-120, P/N V18347-x042x2xx0x Intelligent Positioner	
Input rated	32 V DC; max. 15 mA (powered by a SELV Circuit)
Intrinsically safe with entity parameters of:	
Terminals 11 / 12	V max = 24 V I max = 250 mA C _i = 2.8 nF L _i = 7.2 uH
Terminals 85 / 86	U max = 30 V I max = 50 mA C _i = 3.8 nF L _i = 0 uH
Terminals 41 / 42	U max = 16 V I max = 20 mA C _i = 60 nF L _i = 100 uH

When installed per installation Drawing No 901265	
Temperature Code	T4
Max. Ambient	85 Deg C



IMPORTANT (NOTE)

- The "x" in P/N denotes minor mechanical variations or optional features.
- Local communication interface LKS shall not be used in hazardous location.
- Each pair of conductors of each intrinsic safety circuit shall be shielded.

6.3.2 FM Approvals

TZIDC-120 Positioner, Model V18347-a042b2cd0e
IS/I,II,III/1/ABCDEFG/T6,T5,T4 Ta = 40 °C, 55 °C, 85 °C-901265
Entity, FISCO

Entity and FISCO Parameters							
Terminals	Type	Groups	Parameters				
			Vmax	I _{max}	P _i	C _i	L _i
+11 / -12	Entity	A-G	24 V	250 mA	1.2 W	2.8 nF	7.2 uH
+11 / -12	FISCO	A-G	17.5 V	360 mA	2.52 W	2.8 nF	7.2 uH
+11 / -12	FISCO	C-G	17.5 V	380 mA	5.32 W	2.8 nF	7.2 uH
+51 / -52	Entity	A-G	16 V	20 mA	-	60 nF	100 uH
+41 / -42	Entity	A-G	16 V	20 mA	-	60 nF	100 uH
+85 / -86	Entity	A-G	30 V	-	-	3.7 nF	< 1 uH

NNI/1/2/ABCD/T6,T5,T4 Ta = 40 °C, 55 °C, 85 °C
S/II,III/2/EFG//T6,T5,T4 Ta = 40 °C, 55 °C, 85 °C
Enclosure type 4x
a = Case/mounting – 1, 2, 5 or 6
b = Output/safe protection – 1, 2, 4 or 5
c = 0
d = Optional mechanical kit for digital position feedback – 0, 1 or 3
e = Design (varnish/coding) – 1 or E

Equipment Ratings:
TZIDC-120 Positioners
Intrinsically safe, Entity and FISCO, for Class I, II and III, Division 1,
Applicable Groups A, B, C, D, E, F, G; nonincendive for Class I,
Division 2,
Group E, F and G hazardous (classified) indoor and outdoor NEMA 4x
locations.

The following temperature code ratings were assigned for the equipment and protection methods described above:
T6 in ambient temperatures of 40 °C
T5 in ambient temperatures of 55 °C
T4 in ambient temperatures of 85 °C

6.3.3 FM Control Document

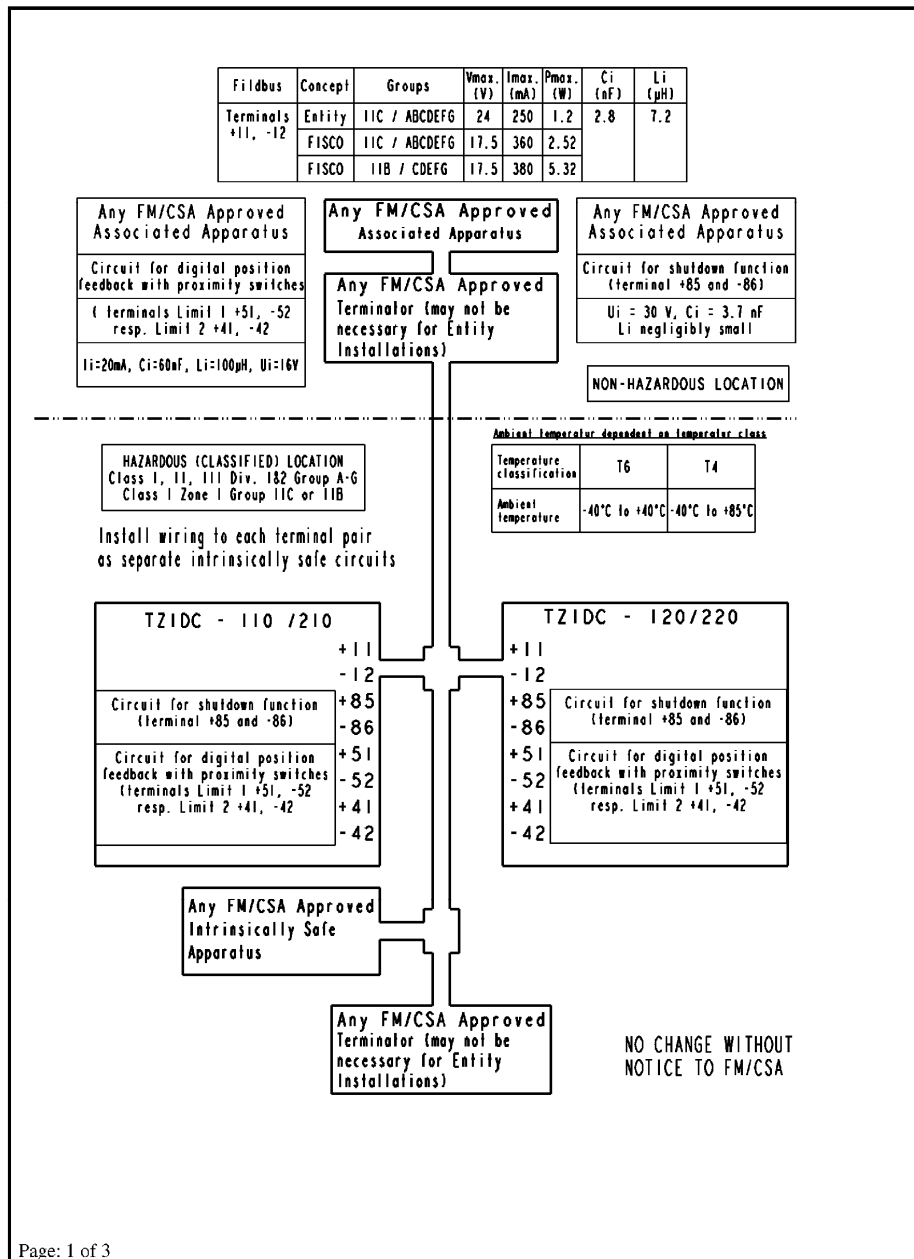

Page: 1 of 3

--				2003	Date	Name	Title	Scale	
					27.03.03	Thiem.	FM/CSA-Control-Document	/	
					Appr.				
					Std.				
3	Rev.2	26.06.06	Thie.	ABB				Drwg.-No. (Part-No.)	
2	Rev.1	22.05.06	Thie.	Automation Products				901265	
1	Rev.0	27.03.	Thie.						
Rev.	Chang	Date	Name					Supersedes Dwg. :	Part Class:

Page: 2 of 3

FM/CSA-CONTROL-DOCUMENT_901265

FISCO rules

The FISCO Concept allows the interconnection of intrinsically safe apparatus to associated apparatus not specifically examined in such combination. The criterion for such interconnection is that the voltage (V_{max}), the current (I_{max}) and the power (P_i) which intrinsically safe apparatus can receive and remain intrinsically safe, considering faults, must be equal or greater than the voltage (U_o, V_o, V_t), the current (I_o, I_{sc}, I_t) and the power (P_o) which can be provided by the associated apparatus (supply unit). In addition, the maximum unprotected residual capacitance (C_i) and inductance (L_i) of each apparatus (other than the terminators) connected to the Fieldbus must be less than or equal to 5nF and 10 μ H respectively.

In each I.S. Fieldbus segment only one active source, normally the associated apparatus, is allowed to provide the necessary power for the Fieldbus system. The allowed voltage (U_o, V_o, V_t) of the associated apparatus used to supply the bus must be limited to the range of 14V d.c. to 24V d.c. All other equipment connected to the bus cable has to be passive, meaning that the apparatus is not allowed to provide energy to the system, except to a leakage current of 50 μ A for each connected device. Separately powered equipment needs a galvanic Isolation to insure that the intrinsically safe Fieldbus circuit remains passive.

The cable used to interconnect the devices needs to comply with the following parameters:

Loop resistance R' : 15...150 Ω /km
 Inductance per unit length L' : 0.4...1mH/km
 Capacitance per unit length C' : 80...200 nF/km
 $C' = C' \text{ line/line} + 0.5C' \text{ line/screen}$, if both lines are floating
 or
 $C' = C' \text{ line/line} + C' \text{ Line/screen}$, if the screen is connected to one line
 Length of spur cable: max. 30m
 Length of trunk cable: max. 1km
 Length of splice: max. 1m

Terminators

At each end of the trunk cable an approved line terminator with the following parameters is suitable:
 $R = 90...100 \Omega$
 $C = 0...2.2 \mu\text{F}$

System evaluation

The number of passive devices like transmitters, actuators, connected to a single bus segment is not limited due to I.S. Reasons. Furthermore, if the above rules are respected, the inductance and capacitance of the cable need not to be considered and will not impair the intrinsic safety of the installation.

-	-			2003	Date	Name	Title	Scale
				Name	27.03.03	Thiem.	FM/CSA-Control-Document	/
				Appr.				
				Std.				
3	Rev.2	26.06.06	Thie.	ABB Automation Products			Drwg.-No. (Part-No.)	
2	Rev.1	22.05.06	Thie.				901265	
1	Rev.0	27.03.	Thie.					
Rev.	Chang	Date	Name				Supersedes Dwg. :	Part Class:

7 Electrical connections

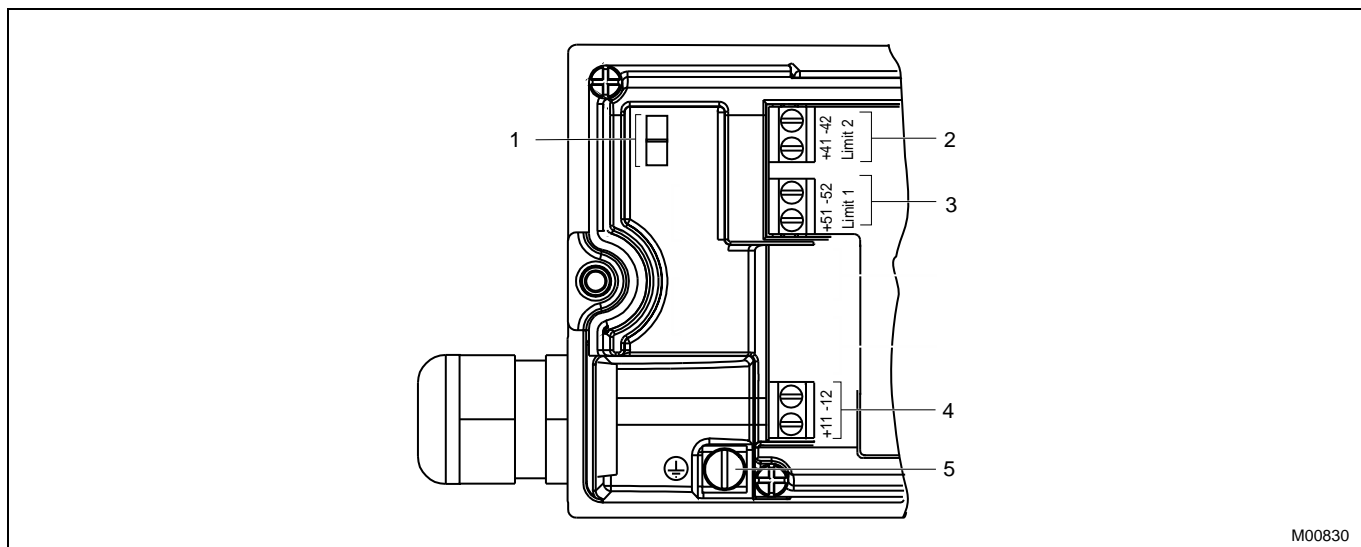
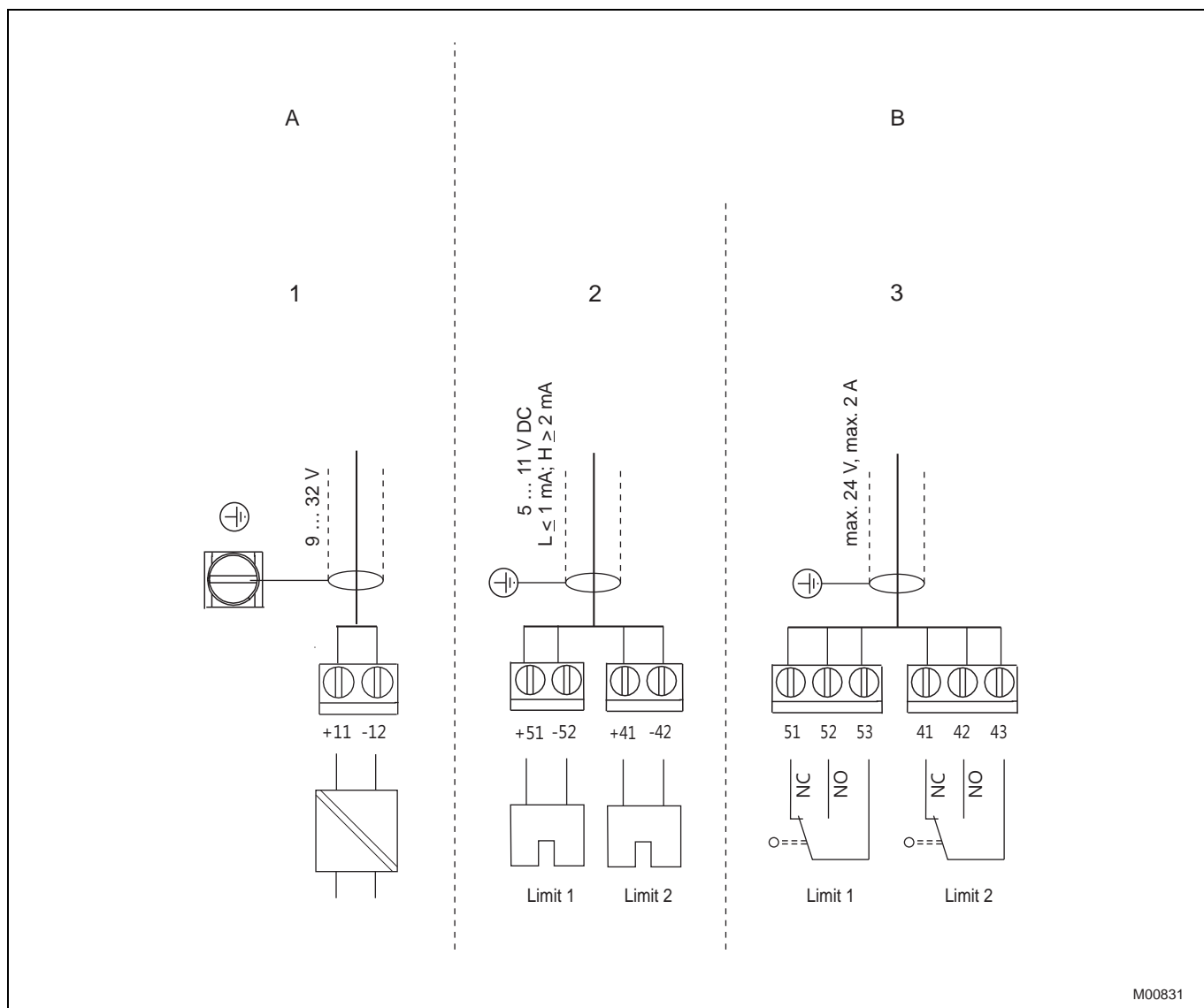

Fig. 6: Screw terminals, overview

- | | | | |
|---|--|---|-----------------|
| 1 | Not assigned | 3 | Same as 4 |
| 2 | Digital position feedback, either proximity switches or 24 V microswitches | 4 | Bus connector |
| | | 5 | Grounding screw |



M00831

Fig. 7: Pin configuration

- A Basic model
- B Options

- 1 Fieldbus, bus feed
- 2 Proximity switches
- 3 Microswitches



Important

Keep cable shields as short as possible and connect on both sides.

8 Dimensions

All dimensions in mm (inch)

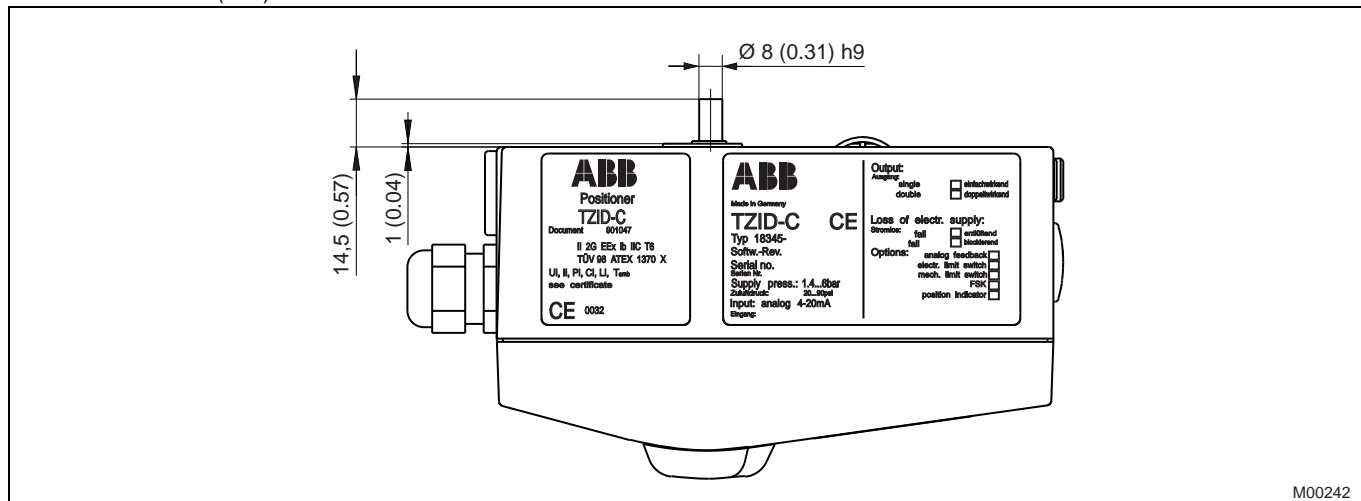

Fig. 8: Top view

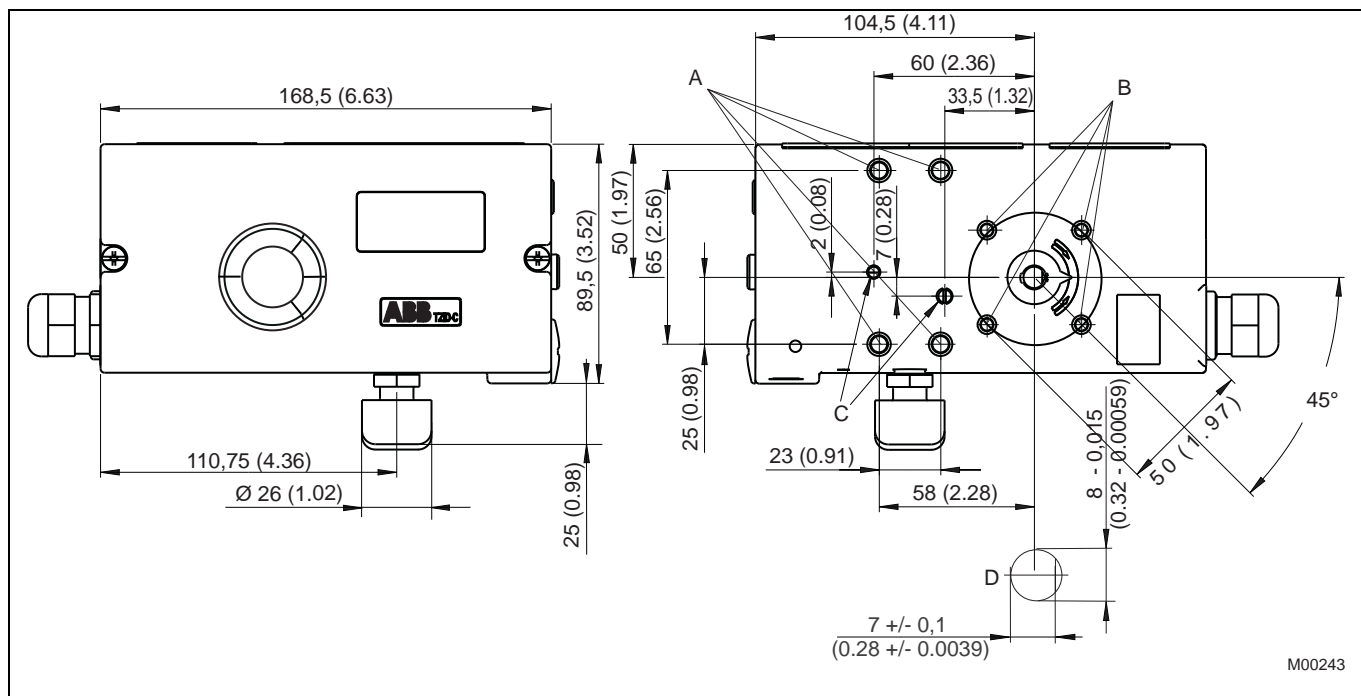

Fig. 9: Front and rear views

- A Tap hole M8 (10 mm low)
- B Tap hole M6 (8 mm low)

- C Tap hole M5 x 0.5 (air vents for direct mount)
- D Sensor shaft (larger than scale)

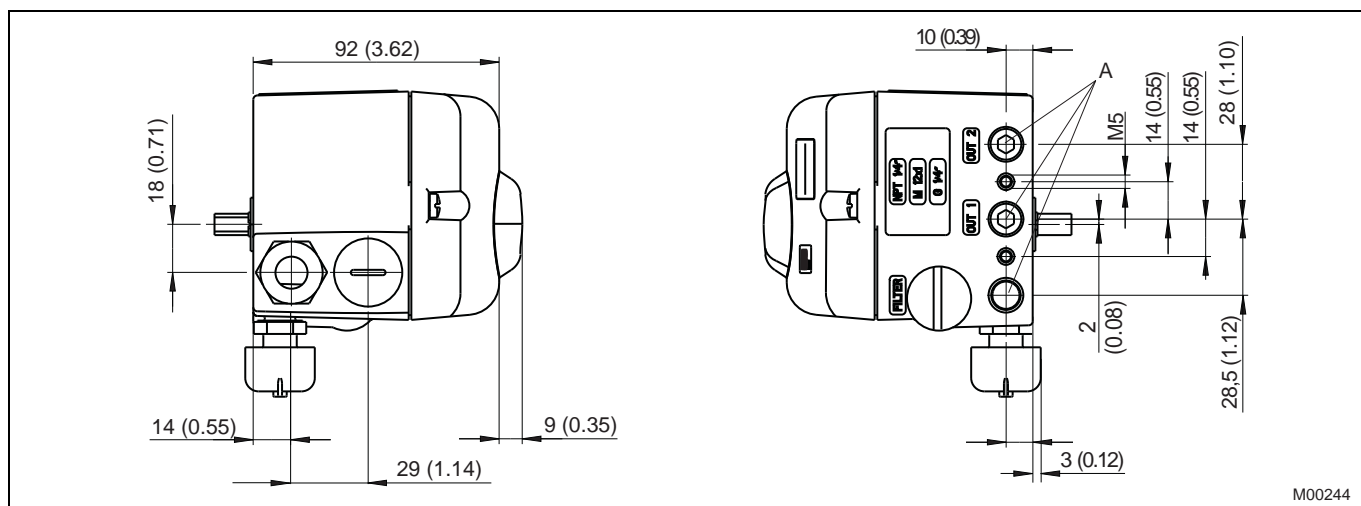

Fig. 10: side view (from left to right)
A Pneumatic connections, NPT 1/4"-18 or G1/4"

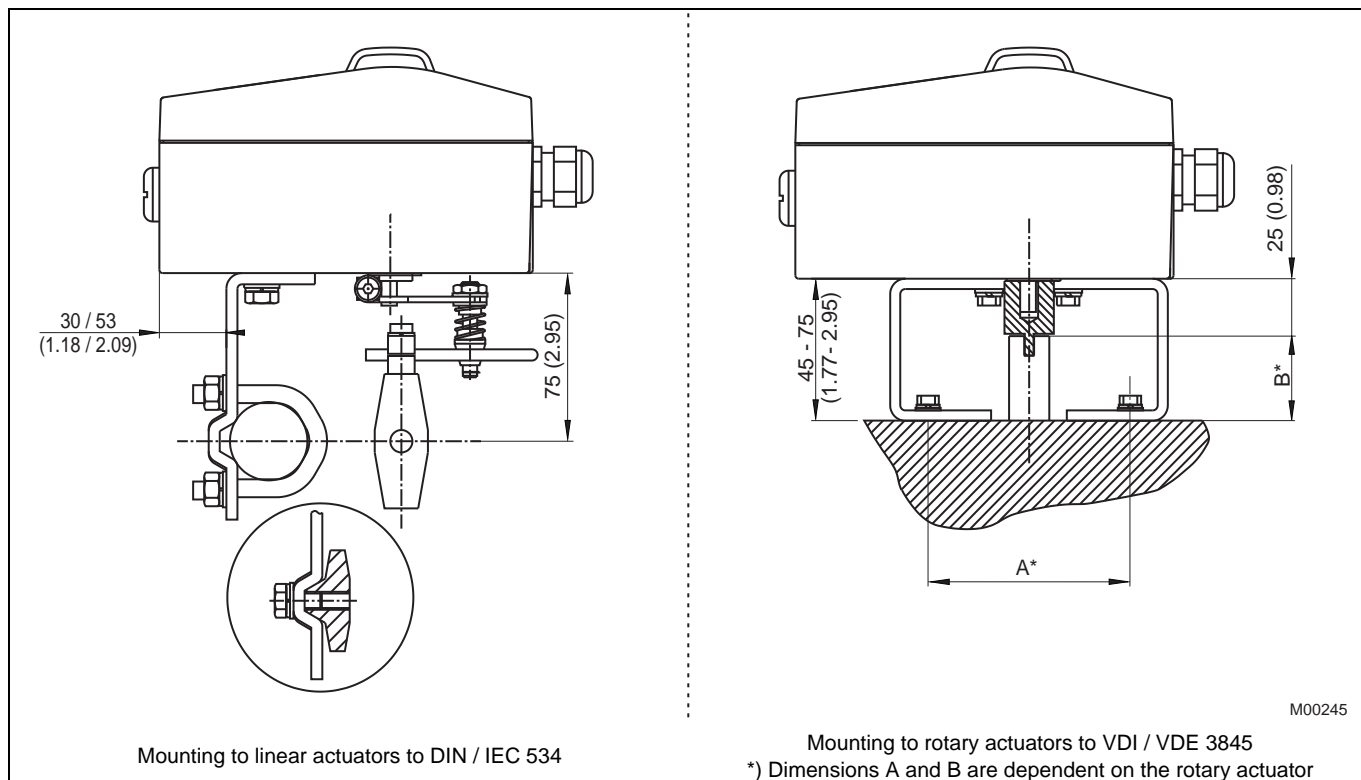

Fig. 11: Mounting drawings

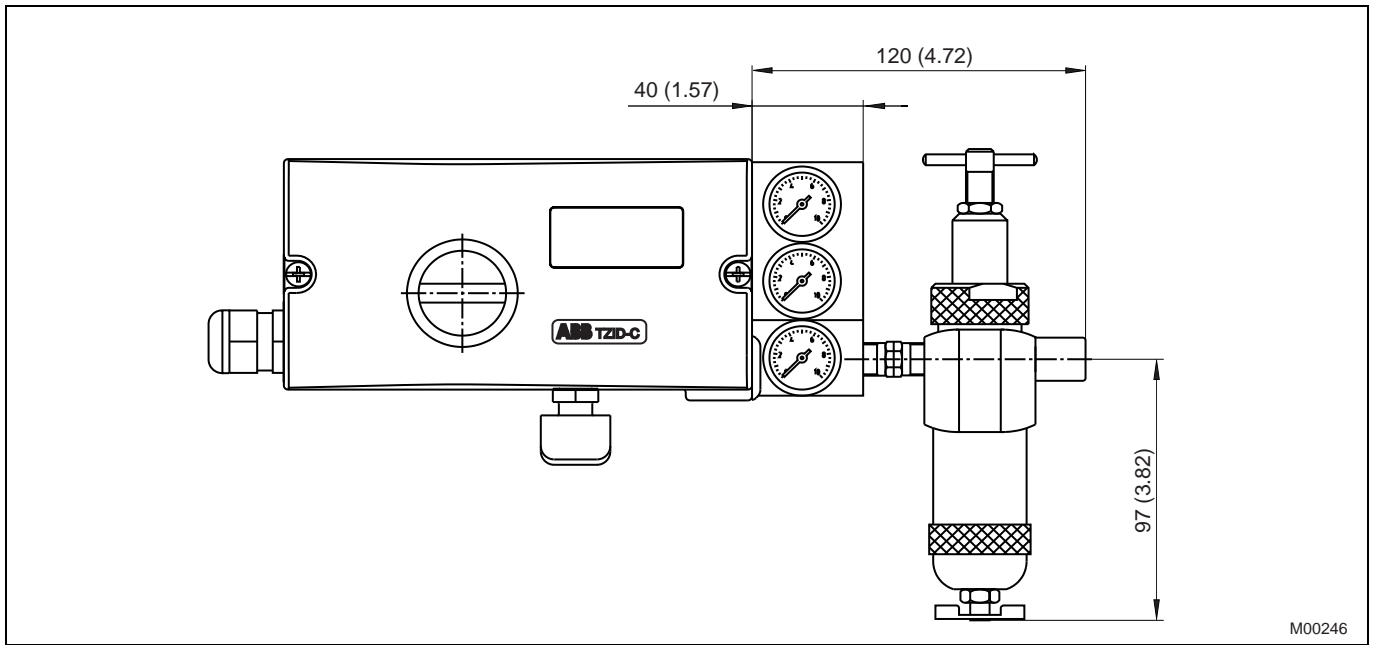

Fig. 12: Positioner TZIDC-120 with pressure gauge block and filter regulator

9 Ordering information

	Main Code											Add. Code	
	Variant digit No.	1 – 6	7	8	9	10	11	12	13	14	15		16
TZIDC-120 Electro-Pneumatic Positioner, for FOUNDATION Fieldbus, intelligent, configurable, with indicator and operator panel	V18347	X	X	X	X	X	X	X	X	X	X	X	XXX
Case / Mounting													XXX
Case made of aluminium, varnished, for mounting to linear actuators acc. DIN/IEC 534 / NAMUR or to rotary actuators acc. VDI/VDE 3845		1	0										
Case made of aluminium, varnished, with mechanical position indicator, for mounting to linear actuators acc. DIN/IEC 534 / NAMUR or to rotary actuators acc. VDI/VDE 3845		2	0										
Case made of aluminium, varnished, for integral mounting to control valves		3	0										
Case made of aluminium, varnished, with mechanical position indicator, for integral mounting to control valves		4	0										
Case made of aluminium, varnished, for mounting to rotary actuators acc. VDI/VDE 3845 with extended rotation angle up to 270°		5	0										
Case made of aluminium, varnished, with mechanical position indicator, for mounting to rotary actuators acc. VDI/VDE 3845 with extended rotation angle up to 270°		6	0										
Input / Communication Port													
FOUNDATION Fieldbus				4									
Explosion Protection													
Without						0							
ATEX II 2 G Ex ia IIC T6 resp. T4 Gb						1							
FM / CSA						2							
ATEX II 3 G Ex nA IIC T6 resp. T4 Gc						4							
IECEX ia IIC T6 resp. T4 Gb						5							
IECEX Ex nA IIC T6 resp. T4 Gc						6							
GOST Russia - Ex II 2 G EEx ia II C T6						A							
GOST Russia - EEx n A II T6						C							
ATEX II 3 G Ex ic IIC T6 resp. T4 Gc						G							
IECEX ic IIC T6 resp. T4 Gc						H							
Output / Safe Position (in case of an electrical power failure)													
Single acting, fail safe						1							
Single acting, fail freeze						2							
Double acting, fail safe						4							
Double acting, fail freeze						5							
Connections													
Cable: Thread 1/2-14 NPT, air pipe: Thread 1/4-18 NPT							2						
Cable: Thread M20 x 1.5, air pipe: Thread 1/4-18 NPT							5						
Cable: Thread M20 x 1.5, air pipe: Thread G 1/4							6						
Cable: Thread G 1/2, air pipe: Thread Rc 1/4							7						
Option Module for Shutdown Function													
Without								0					
Optional Mechanical Kit for Digital Position Feedback													
Without									0	0			
Mechanic Mechanical kit for digital position feedback with proximity switches SJ2-SN (NC or logical 1)									1)	1	0		
Mechanical kit for digital position feedback with 24 V AC / DC microswitches (change-over contacts)									2)	5	0		

Continued on next page

- 1) Only for model with mechanical position indicator, no IECEx
- 2) Not for explosion protected version and only for model with mechanical position indicator

	Main Code											Add. Code
	Variant digit No.	1 – 6	7	8	9	10	11	12	13	14	15	
TZIDC-120 Electro-Pneumatic Positioner, for FOUNDATION Fieldbus, intelligent, configurable, with indicator and operator panel	V18347	X	X	X	X	X	X	X	X	X	X	X
Design (Varnish / Coding)												
Standard												1
Special version for Chemical Industries												3) E
Documentation Language												
German												M1
Italian												M2
Spanish												M3
French												M4
English												M5
Swedish												M7
Finnish												M8
Polish												M9
Portuguese												MA
Russian												MB
Czech												MC
Dutch												MD
Danish												MF
Greek												MG
Latvian												ML
Hungarian												MM
Estonian												MO
Bulgarian												MP
Romanian												MR
Slovak												MS
Lithuanian												MU
Slovenian												MV
Certificate of Compliance												
Certificate of compliance with the order acc. EN 10204-2.1 (DIN 50049-2.1) with item description												CF2
Test report 2.2 acc. EN 10204 (DIN 50049-2.2)												CF3
Inspection Certificate												
Inspection certificate 3.1 acc. EN 10204												CBA
Device Identification Label												
Stainless steel 11.5 x 60 mm (0.45 x 2.36 in.)												MK1
Sticker 11 x 25 mm (0.43 x 0.98 in.)												MK3

3) Details on request

9.1 Accessories

Accessories	Order number
Mounting bracket	
EDP300 / TZIDC Mounting bracket for rotary actuators (mounting to VDI / VDE 3845), dimension A/B = 80/20 mm	319603
EDP300 / TZIDC Mounting bracket for rotary actuators (mounting to VDI / VDE 3845), dimension A/B = 80/30 mm	319604
EDP300 / TZIDC Mounting bracket for rotary actuators (mounting to VDI / VDE 3845), dimension A/B = 130/30 mm	319605
EDP300 / TZIDC Mounting bracket for rotary actuators (mounting to VDI / VDE 3845), dimension A/B = 130/50 mm	319606
Lever	
EDP300 / TZIDC Lever 30 mm	7959151
EDP300 / TZIDC Lever 100 mm	7959152
Adapter	
EDP300 / TZIDC Adapter (shaft coupler) for rotary actuators (mounting to VDI / VDE 3845)	7959110
EDP300 / TZIDC Form - locking shaft adapter	7959371
Pressure gauge block	
TZIDC Pressure gauge block, 0.6 MPa, single acting, G 1/4 connection	7959364
TTZIDC Pressure gauge block, 0.6 MPa, single acting, Rc 1/4 connection	7959358
TZIDC Pressure gauge block, 0.6 MPa, single acting, NPT 1/4 connection	7959360
TZIDC Pressure gauge block, 0.6 MPa, double acting, G 1/4 connection	7959365
TZIDC Pressure gauge block, 0.6 MPa, double acting, Rc 1/4 connection	7959359
TZIDC Pressure gauge block, 0.6 MPa, double acting, NPT 1/4 connection	7959361
Filter regulator	
TZIDC Filter regulator, brass, connections thread G 1/4, incl. material for mounting to pressure gauge block	7959119
TTZIDC Filter regulator, brass, connections thread 1/4-18 NPT, incl. material for mounting to pressure gauge block	7959120
Attachment kit	
EDP300 / TZIDC Attachment kit for linear actuators, stroke 10 ... 35 mm	7959125
EDP300 / TZIDC Attachment kit for linear actuators, stroke 20 ... 100 mm	7959126
EDP300 / TZIDC Attachment for remote sensor control unit (for wall or pipe mounting)	7959381
EDP300 / TZIDC Attachment kit for Fisher 1051-30, 1052-30	7959214
EDP300 / TZIDC Attachment kit for Fisher 1061 size 130	7959206
EDP300 / TZIDC Attachment kit for Fisher 471	7959195
EDP300 / TZIDC Attachment kit for Fisher 657 / 667 Size 10 ... 90 mm	7959177
EDP300 / TZIDC Attachment kit for Fisher Gulde 32/34	7959344
EDP300 / TZIDC Attachment kit for Gulde DK	7959161
EDP300 / TZIDC Attachment kit for Keystone 79U/E-002(S) ... 79U/E-181(S)	7959147
EDP300 / TZIDC Attachment kit for Masoneilan CAMFLEX II, VARIMAX, MINITORK II	7959144
EDP300 / TZIDC Attachment kit for Masoneilan VariPak 28000 series	7959163
EDP300 / TZIDC Attachment kit for MaxFlo MaxFlo	7959140
EDP300 / TZIDC Attachment kit for NAF 791290	7959207
EDP300 / TZIDC Attachment kit for NAMUR stroke 100 ... 170 mm	7959339
EDP300 / TZIDC Attachment kit for NELES BC6-20, B1C6-20, BJ8-20, B1J8-20	7959146
EDP300 / TZIDC Attachment kit for Valves Nuovo Pignone, lever for linear stroke, length 150 ... 250 mm	7959210
EDP300 / TZIDC Attachment kit for Samson 241, 271, 3271	7959145
EDP300 / TZIDC Attachment kit for Samson 3277	7959136
EDP300 / TZIDC Attachment kit for Schubert&Salzer GS 8020 / 8021 / 8023	7959200
EDP300 / TZIDC Attachment kit for SED SED stroke 100 mm	7959141
EDP300 / TZIDC Mounting Kit Uhde Type 4 Stroke 400 mm cropped	7959500

Notes

Contact us

ABB Limited

Process Automation

Howard Road, St. Neots
Cambridgeshire, PE19 8EU
UK

Tel: +44 (0)870 600 6122

Fax: +44 (0)1480 213 339

Mail: enquiries.mp.uk@gb.abb.com

ABB Inc.

Process Automation

125 E. County Line Road
Warminster, PA 18974
USA

Tel: +1 215 674 6000

Fax: +1 215 674 7183

ABB Automation Products GmbH

Process Automation

Schillerstr. 72
32425 Minden
Germany

Tel: +49 571 830-0

Fax: +49 571 830-1806

www.abb.com/positioners

Note

We reserve the right to make technical changes or modify the contents of this document without prior notice. With regard to purchase orders, the agreed particulars shall prevail. ABB does not accept any responsibility whatsoever for potential errors or possible lack of information in this document.

We reserve all rights in this document and in the subject matter and illustrations contained therein. Any reproduction, disclosure to third parties or utilization of its contents - in whole or in parts - is forbidden without prior written consent of ABB.

Copyright© 2016 ABB

All rights reserved

3KXE341003R1001



Sales



Service



Software