

Fisher™ 2500 and 2503 Controllers and Transmitters

Contents

- Introduction 2
 - Scope of Manual 2
 - Description 2
 - Specifications 2
 - Educational Services 2
- Installation 5
 - Sensor Assembly 6
 - Uncrating 6
 - Controller/Transmitter Orientation 7
 - Mounting Caged Sensor 8
 - Mounting Cageless Sensor 10
 - Side-Mounted Sensor 10
 - Top-Mounted Sensor 12
 - Supply and Output Pressure Connection 12
 - Supply Pressure 12
 - Controller/Transmitter Output Connection .. 13
 - Vent Assembly 13
- Prestartup Checks 14
 - 2500 Controller or 2500T Transmitter 17
 - 2500S Controller 18
 - 2503 Controller 18
 - Adjustments 19
 - Control Action 19
 - Level Adjustment (Controllers Only) 19
 - Zero Adjustment (Transmitters Only) 20
 - Proportional Band Adjustment
(Except Transmitters and 2503
Controllers) 20
 - Specific Gravity Adjustment
(Transmitters Only) 20
- Calibration 20
 - Precalibration Requirements 20
 - Wet Calibration 20
 - Dry Calibration 21
 - Controller/Transmitter and Torque Tube Arm
Disassembly 21
 - Determining the Amount of
Suspended Weight 21
 - Calibration Procedure 22
 - 2500 Controller and 2500T Transmitter 23
 - 2500S and 2503 Controllers 25
- Startup 27
 - 2500 Controller 27
 - 2500T Transmitter 27
 - 2500S Controller 27
 - 2503 Controller 27

Figure 1. Fisher 2500 or 2503 Controller/Transmitter on 249 Caged Sensor

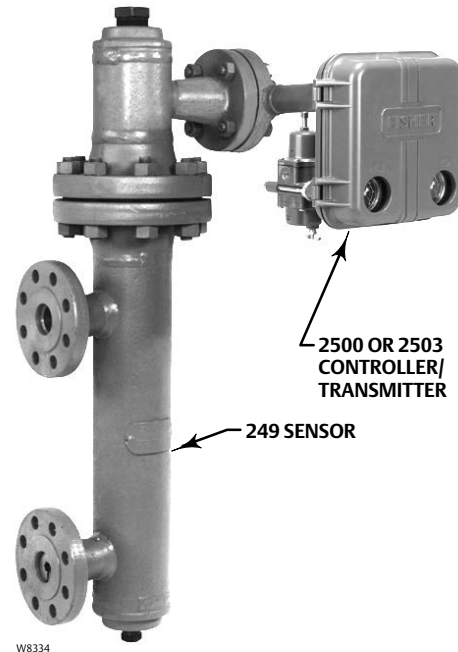

- Principle of Operation 27
 - 2500 Controller or 2500T Transmitter 28
 - Proportional Valve 28
 - 2500S Controller 28
 - 2503 Controller 29
- Maintenance 30
 - Troubleshooting 31
 - Removing Controller/Transmitter from Sensor .. 32
 - Changing Mounting Methods 33
 - Installing Controller/Transmitter on Sensor 34
 - Replacing the Bourdon Tube 35
 - Changing Action 35
 - Relay Deadband Testing (2500 Controller
or 2500T Transmitter Only) 36
 - Replacing the Proportional Valve 37
 - Changing Relay 37
- Parts Ordering 37
- Parts List 38

Introduction

Scope of Manual

This manual provides installation, operating, calibration, maintenance, and parts ordering information for 2500 and 2503 pneumatic controllers and transmitters used in combination with 249 displacer sensors.

Note

This manual does not include installation or maintenance procedures for the supply pressure regulator, sensor, or other devices. For that information, refer to the appropriate instruction manual for the other device.

Do not install, operate, or maintain a 2500 or 2503 pneumatic controller/transmitter without being fully trained and qualified in valve, actuator, and accessory installation, operation, and maintenance. To avoid personal injury or property damage, it is important to carefully read, understand, and follow all contents of this quick start guide, including all safety cautions and warnings. If you have any questions about these instructions, contact your [Emerson sales office](#) or Local Business Partner before proceeding.

Description

These instruments control or transmit the fluid level, the level of interface between two fluids, or the density (specific gravity). Each unit consists of a 249 displacer-type fluid level sensor and a 2500 or 2503 pneumatic controller or transmitter. Figure 1 shows a typical controller-sensor combination.

Specifications

Refer to table 1 for specifications.

Educational Services

For information on available courses for 2500 or 2503 controller/transmitter as well as a variety of other products, contact:

Emerson Automation Solutions
Educational Services - Registration
Phone: 1-641-754-3771 or 1-800-338-8158
E-mail: education@emerson.com
emerson.com/fishervalvetraining

Table 1. Specifications

<p>Available Configurations⁽¹⁾ 2500—Proportional-only controller 2500C—Proportional-only controller with indicator (see figure 10) 2500R—Reverse acting proportional-only controller 2500S—Differential gap (snap acting) controller. See changing controller action procedure and figure 15 2500T—Transmitter 2503—Differential gap controller without proportional valve; for applications requiring very little adjustment</p> <p>Input Signal Fluid Level or Fluid-to-Fluid Interface Level: From 0 to 100% of displacer length—standard lengths for all sensors are 356 mm or 812 mm (14 inches or 32 inches). Other lengths available depending on sensor construction. Fluid Density: From 0 to 100% of displacement force change obtained with given displacer volume. Standard volume for displacers are listed in table 2.</p> <p>Output Signal 2500 Controller and 2500T Transmitter: 0.2 to 1 bar (3 to 15 psig) or 0.4 to 2 bar (6 to 30 psig) 2500S and 2503 Differential Gap Controllers: 0 bar (0 psig) when switched off and full supply [1.4 or 2.4 bar (20 or 35 psig) nominal depending on controller output pressure range] when switched on.</p> <p>Area Ratio of Relay Diaphragms 3:1</p> <p>Supply Pressure Data See table 3⁽²⁾</p> <p>Supply Medium Air or Natural Gas Supply medium must be clean, dry, and noncorrosive Per ISA Standard 7.0.01 A maximum 40 micrometer particle size in the air system is acceptable. Further filtration down to 5 micrometer particle size is recommended. Lubricant content is not to exceed 1 ppm weight (w/w) or volume (v/v) basis. Condensation in the air supply should be minimized</p>	<p>Per ISO 8573-1 <i>Maximum particle density size:</i> Class 7 <i>Oil content:</i> Class 3 <i>Pressure Dew Point:</i> Class 3 or at least 10°C less than the lowest ambient temperature expected</p> <p>Maximum Supply Pressure^(2,3) 3 bar (45 psig) to the controller or transmitter. If controller or transmitter is equipped with an integrally mounted 67CFR filter/regulator, typical supply pressure to the regulator is from 2.5 bar (35 psig) to 17 bar (250 psig), maximum. For supply pressures to the filter/regulator, refer to the appropriate regulator instruction manual.</p> <p>Steady-State Air Consumption 2500 Controllers and Transmitters (2500, 2500C, 2500R, 2500S, and 2500T): See table 3 2503 Controller: Vents only when relay is exhausting</p> <p>Proportional Band Adjustment (Proportional-Only Controllers) Full output pressure change adjustable over 10 to 100% of displacer length⁽⁴⁾</p> <p>Differential Gap Adjustment (Differential Gap Controllers) 2500S Controller: Full output pressure change adjustable from 20 to 100% of displacer length.⁽⁴⁾ 2503 Controller: Full output pressure change adjustable over approximately 25 to 40% of displacer length⁽⁴⁾</p> <p>Span Adjustment (2500T Transmitter) Full output pressure change adjustable from 20 to 100% of displacer length⁽⁴⁾</p> <p>Set Point (controllers only) or Zero (transmitters only) Adjustment For proportional-only controllers or transmitters, level adjustment positions the set point or zero for the fluid level, interface level, or displacer force change (density) within the displacer length. For differential gap controllers, level adjustment simultaneously positions both ends of the gap within the displacer length.</p>
---	---

(continued)

Table 1. Specifications (Continued)

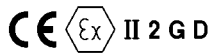
<p>Performance</p> <p>Independent Linearity (transmitters only): 1% of output pressure change for 100% span.</p> <p>Hysteresis: 0.6% of output pressure change at 100% proportional band, differential gap, or span</p> <p>Repeatability: 0.2% of displacer length or displacement force change</p> <p>Deadband (except differential gap controllers⁽⁵⁾): 0.05% of proportional band or span</p> <p>Typical Frequency Response: 4 Hz and 90 degree phase shift at 100% proportional band with output piped to typical instrument bellows using 6.1 meters (20 feet) of 1/4-inch tubing</p> <p>Ambient Operating Temperature Limits⁽³⁾</p> <p>For ambient temperature ranges and guidelines for use of the optional heat insulator assembly, see figure 2. Relay temperature limits are:</p> <p>Standard Construction: -40 to 71°C (-40 to 160°F)</p> <p>High-Temperature Construction: -18 to 104°C (0 to 220°F)</p>	<p>Typical Ambient Temperature Operating Influence</p> <p>Output pressure changes $\pm 1.5\%$ per 10°C (50°F) change in temperature at 100% proportional band when using a standard wall torque tube with 249 sensors</p> <p>Hazardous Area Classification</p> <p>2500 and 2503 controllers/transmitters comply with the requirements of ATEX Group II Category 2 Gas and Dust</p> <p></p> <p>Supply and Output Connections</p> <p>1/4 NPT internal</p> <p>Maximum Working Pressure (sensors only)</p> <p>Refer to the appropriate sensor instruction manual</p>
---	---

NOTE: Specialized instrument terms are defined in ANSI/ISA Standard 51.1 - Process Instrument Terminology.

1. Controllers are field adjustable between direct or reverse action. The letter R in the type number indicates that the controller/transmitter shipped from the factory set for reverse action (see changing controller action procedures). The letter C in the type number indicates that a pointer is attached to the torque tube shaft providing visual monitoring of torque tube motion.
2. Control and stability may be impaired if the maximum pressures are exceeded.
3. The pressure/temperature limits in this document, and any applicable standard or code limitation should not be exceeded.
4. These statements apply only to units sized to produce a full output change for a 100% level change at the maximum proportional band dial setting.
5. Adjusting the span of the differential gap controller is equivalent to adjusting the deadband.

Table 2. Standard Displacer Volumes

Sensor	Standard Volume Liters	Standard Volume Cubic Inches
249, 249B, 249BF, 249BP, 249K, 249P, 249W	1.6	100 ⁽¹⁾
249C, 249CP, 249W	1.0	60 ⁽²⁾
249L	1.9	120
249VS	1.3 ⁽³⁾	80 ⁽³⁾

1. For 249W, with standard 812 mm (32-inch) displacer.
2. For 249W, with standard 356 mm (14-inch) displacer.
3. With standard 305 mm (12-inch) flange-face-to-displacer centerline dimension only.

Table 3. Supply Pressure Data

OUTPUT SIGNAL RANGE	STANDARD SUPPLY AND OUTPUT PRESSURE GAUGE INDICATIONS ⁽¹⁾	NORMAL OPERATING SUPPLY PRESSURE ⁽²⁾		AIR CONSUMPTION AT NORMAL OPERATING SUPPLY PRESSURE		MAXIMUM SUPPLY PRESSURE
		Bar	Psig	Minimum ⁽³⁾	Maximum ⁽⁴⁾	
0.2 to 1 bar (3 to 15 psig)	0 to 30 psig	1.4	20	4.2 scfh ⁽⁵⁾	27 scfh ⁽⁵⁾	3 bar (45 psig)
0.4 to 2 bar (6 to 30 psig)	0 to 60 psig	2.4	35	7 scfh ⁽⁵⁾	42 scfh ⁽⁵⁾	3 bar (45 psig)

1. Consult your Emerson Automation Solutions sales office about gauges in other units.
2. Control and stability may be impaired if this pressure is exceeded.
3. At zero or maximum proportional band or specific gravity setting.
4. At setting in middle of proportional band or specific gravity range.
5. If air consumption is desired in normal m³/hr at 0°C and 1.01325 bar, multiply scfh by 0.0258.

Figure 2. Guidelines for Use of Optional Heat Insulator Assembly

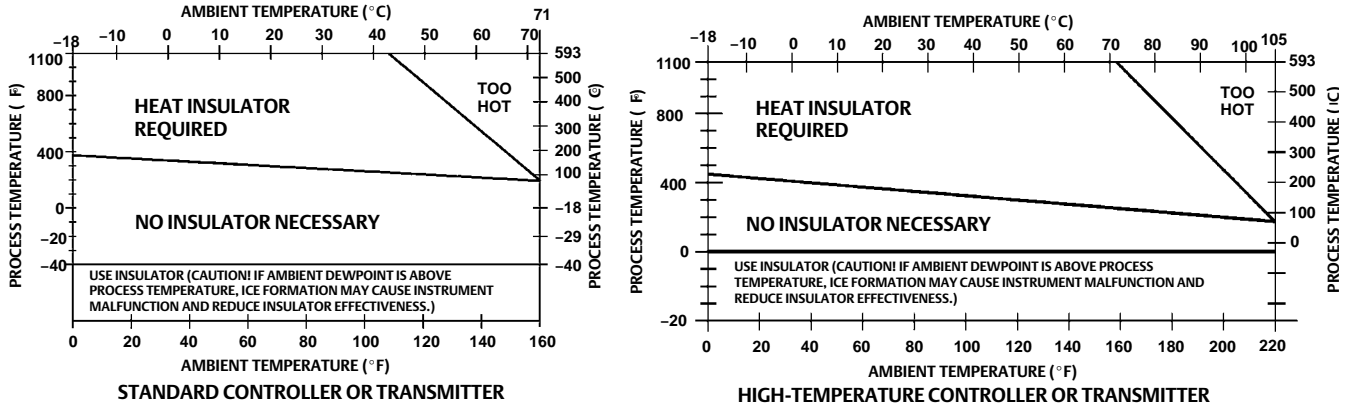

NOTE:
FOR APPLICATIONS BELOW -29°C (-20°F), BE SURE THE SENSOR MATERIALS OF CONSTRUCTION ARE APPROPRIATE FOR THE SERVICE TEMPERATURE.

CV6190-E
B1413-3

thank

Table 4. Displacer and Torque Tube Materials

Part	Standard Material	Other Materials
Displacer	304 Stainless Steel	316 Stainless Steel, N10276, N04400, Plastic, and Special Alloys
Displacer Stem, Driver Bearing, Displacer Rod and Driver	316 Stainless Steel	N10276, N04400, other Austenitic Stainless Steels, and Special Alloys
Torque Tube	N05500 ⁽¹⁾	316 Stainless Steel, N06600, N10276

1. N05500 is not recommended for spring applications above 232°C (450°F). Contact your [Emerson sales office](#) or application engineer if temperatures exceeding this limit are required.

Installation

2500 and 2503 controller/transmitters work in combination with 249 displacer-type sensors. The factory attaches the controller/transmitter to the sensor, unless it is ordered separately.

If using natural gas as the pneumatic supply medium, natural gas will be used in the pressure connections of the unit to any connected equipment. The unit will vent natural gas into the surrounding atmosphere.

⚠ WARNING

Always wear protective clothing, gloves, and eyewear when performing any installation operations to avoid personal injury.

Check with your process or safety engineer for any additional measures that must be taken to protect against process media.

If installing into an existing application, also refer to the WARNING at the beginning of the Maintenance section in this instruction manual.

CAUTION

Do not use sealing tape on pneumatic connections. This instrument contains small passages that may become obstructed by detached sealing tape. Thread sealant paste should be used to seal and lubricate pneumatic threaded connections.

⚠ WARNING

Personal injury or property damage may result from fire or explosion if natural gas is used as the supply medium and preventive measures are not taken. Preventive measures may include, but are not limited to, one or more of the following: Remote venting of the unit, re-evaluating the hazardous area classification, ensuring adequate ventilation, and the removal of any ignition sources. For information on remote venting of this controller refer to page 13.

Sensor Assembly

Table 2 lists sensors recommended for use with controller/transmitters. Table 4 contains displacer and torque tube materials. For sensor installation and maintenance, refer to the appropriate sensor instruction manual.

⚠ WARNING

When replacing the sensor assembly, the displacer may retain process fluid or pressure. Personal injury or property damage may occur due to sudden release of the pressure. Contact with hazardous fluid, fire, or explosion can be caused by puncturing, heating, or repairing a displacer retaining process pressure or fluid. This danger may not be readily apparent when disassembling the sensor assembly or removing the displacer. Before disassembling the sensor or removing the displacer, observe the more specific warning provided in the sensor instruction manual.

Uncrating

Unless ordered separately, the controller/transmitter is attached to the sensor when shipped. Carefully uncrate the assembly.

CAUTION

Sensors used for interface or density control may be so large and heavy that the torque tube cannot fully support their weight in air. On the 249VS, a travel stop is used to prevent damage. Do not remove this travel stop assembly without first removing the displacer from the displacer rod. Refer to the appropriate instruction manual for 249 cageless sensors.

Note

Caged sensors have rods and blocks installed at each end of the displacers to protect the displacers in shipping. Remove these parts before you install the sensor to allow the displacer to function properly.

Caged sensors come with the displacer installed in the cage. If a tubular gauge glass is ordered with the sensor, the gauge glass is crated separately and must be installed at the site. A damping plate is installed in the lower screwed or flanged connection (see figure 3) to provide more stable operation. Be certain that the cage equalizing connections and the damping plate are not plugged by foreign material.

Figure 3. Damping Plate Location

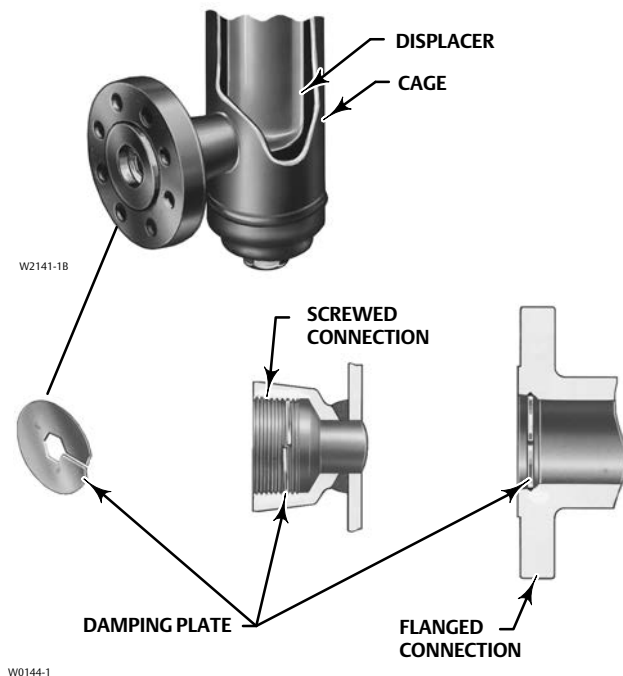

A cageless sensor comes with its displacer separated from the sensor assembly. Displacers longer than 813 mm (32 inches) come in a separate crate. Shorter displacers come in the same crate as the sensor, but are not attached to their displacer rods. Inspect the displacer to ensure it is not dented. A dent may reduce the pressure rating of the displacer. If a displacer is dented, replace it.

Controller/Transmitter Orientation

The controller/transmitter attaches to the sensor in one of the mounting positions shown in figure 4. Right-hand mounting is with the controller or transmitter case to the right of the displacer when you look at the front of the case; left-hand mounting is with the case to the left of the displacer. The mounting position can be changed in the field. Changing this mounting position changes the control action from direct to reverse, or vice versa.

All caged sensors have a rotatable head. That is, the controller/transmitter may be positioned at any of eight alternate positions around the cage as indicated by the numbers 1 through 8 in figure 4. To rotate the head, remove the head flange bolts and nuts and position the head as desired.

Figure 4. Cage Head Mounting Positions

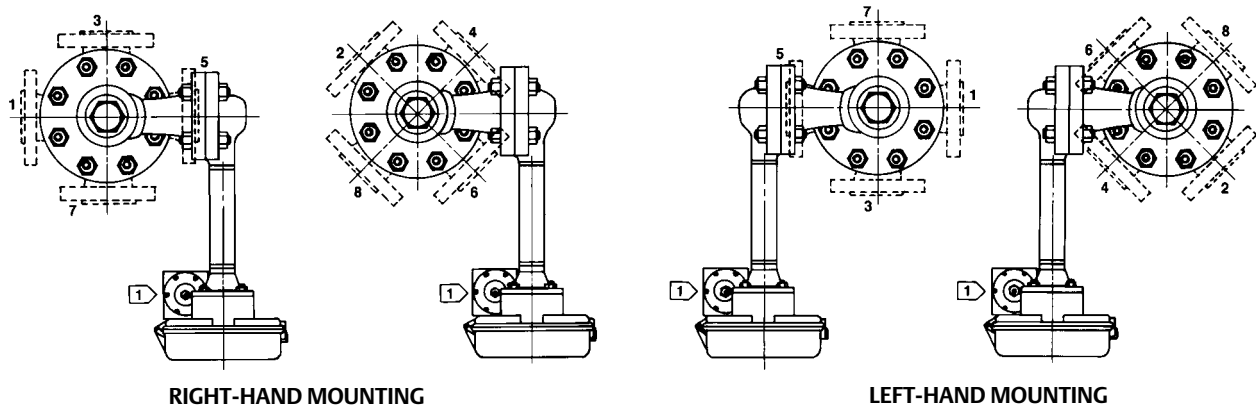

1 67CFR FILTER/REGULATOR.
AH9150-A
A2613-2

Mounting Caged Sensor

Note

Install the cage so that it is plumb; the displacer must not touch the cage wall. If the displacer touches the cage wall, the unit will transmit an erroneous output signal.

Note

If the controller/transmitter is not mounted on the sensor, refer to the Installing Controller/Transmitter on Sensor procedures in the Maintenance section. This section also provides instructions for adding a heat insulator to a unit.

Cage connections normally are either NPS 1-1/2 or 2, screwed or flanged. Figure 5 shows the combinations. With flanged connections, use standard gaskets or other flat-sheet gaskets compatible with the process fluid. Spiral-wound gaskets without compression-controlling centering rings cannot be used for flange connections.

Figure 5. Cage Connection Styles

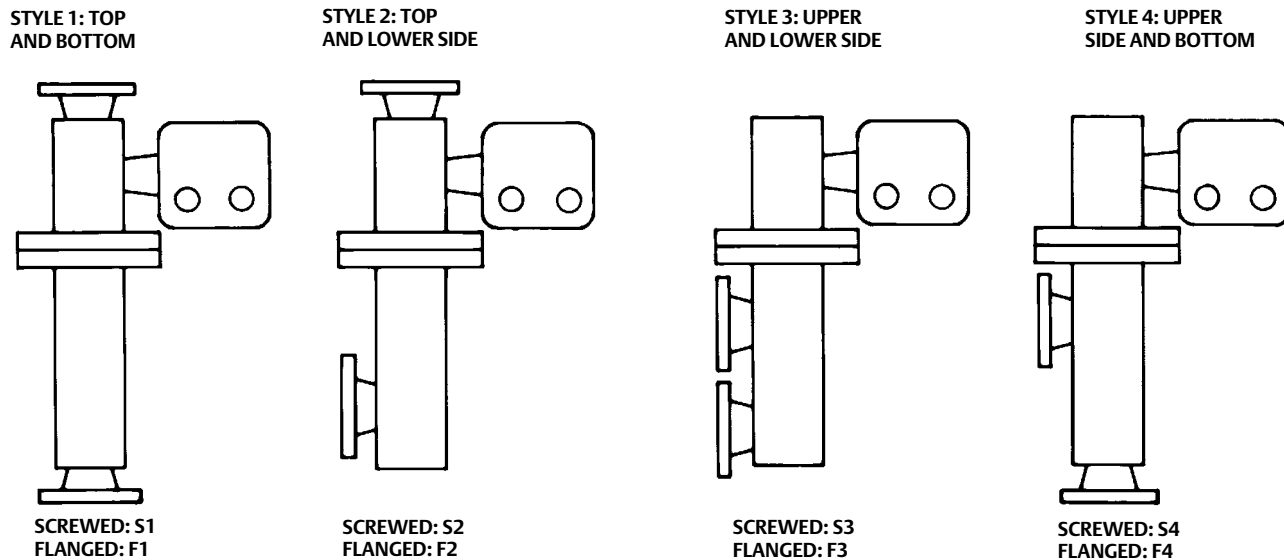

A1271-2

As shown in figure 6, mount the cage by running equalizing lines between the cage connections and the vessel. A shutoff or hand valve with a 1-1/2 inch diameter or larger port should be installed in each of the equalizing lines. Also install a drain between the cage and shutoff or hand valve whenever the bottom cage line has a fluid-trapping low point.

Figure 6. Caged Sensor Mounting

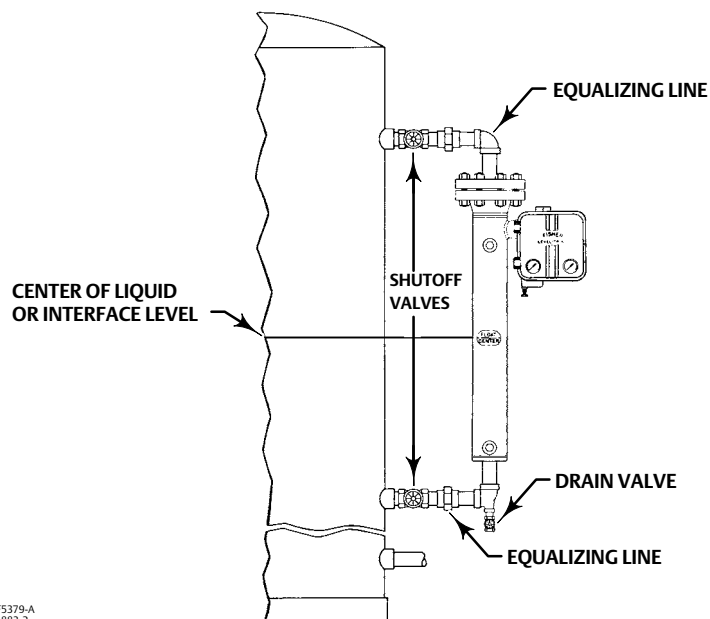

DF5379-A
 A1883-2

On fluid or interface level applications, position the sensor so that the center line on the cage (see figure 6) is as close as possible to the center of the fluid level or interface level range being measured. Also consider installing a gauge glass on the vessel, or on the sensor cage (if the cage is tapped for a gauge).

Mounting Cageless Sensor

Note

If a stillwell is used, install it plumb so that the displacer does not touch the wall of the stillwell. If the displacer touches the wall, the unit will transmit an erroneous output signal.

Since the displacer hangs inside the vessel, provide a stillwell around the displacer if the fluid is in a state of continuous agitation to avoid excessive turbulence around the displacer.

Note

Displacers used in an interface level application must be completely submerged during operation. If displacers aren't completely submerged, they will not calibrate or perform properly. To obtain the desired controller or transmitter sensitivity may require using either a thin-wall torque tube, an oversized displacer, or both.

Note

If the controller/transmitter is not mounted on the sensor, refer to the Installing Controller/Transmitter on Sensor procedures in the Maintenance section. This section also provides instructions for adding a heat insulator to a unit.

Attach a cageless sensor to a flanged connection on the vessel as shown in figure 7. For interface or fluid level applications, install a gauge glass on the vessel.

Side-Mounted Sensor

If a stillwell is required (see figure 7), attach the displacer to the displacer rod from inside the vessel.

Connect the displacer as shown in figure 8, locking the assembly with the cotter spring provided. If a stillwell is not required, attach the displacer rod before mounting the sensor on the vessel. Then, you can swing the displacer out horizontally for insertion into the vessel. However, once the sensor is installed and the displacer drops to a vertical position, the displacer may not be capable of being withdrawn for servicing later. Be sure there is another access to the displacer to permit swinging it to a horizontal position or to permit disconnecting it from the displacer rod.

If an extension is used between the displacer spud and the displacer stem end piece, make sure the nuts are tight at each end of the displacer stem extension. Install and tighten suitable bolting or cap screws in the flanged connection to complete the installation.

Figure 7. Cageless Sensor Mounting

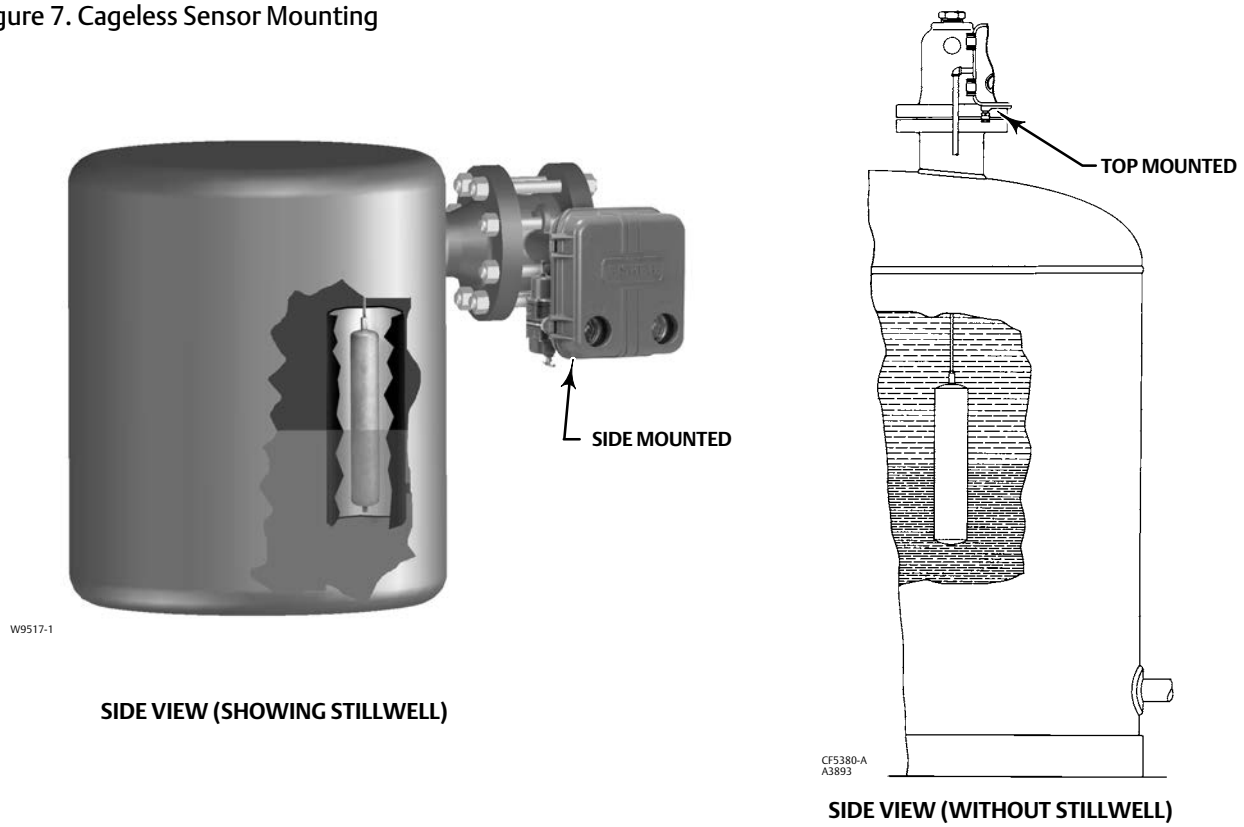
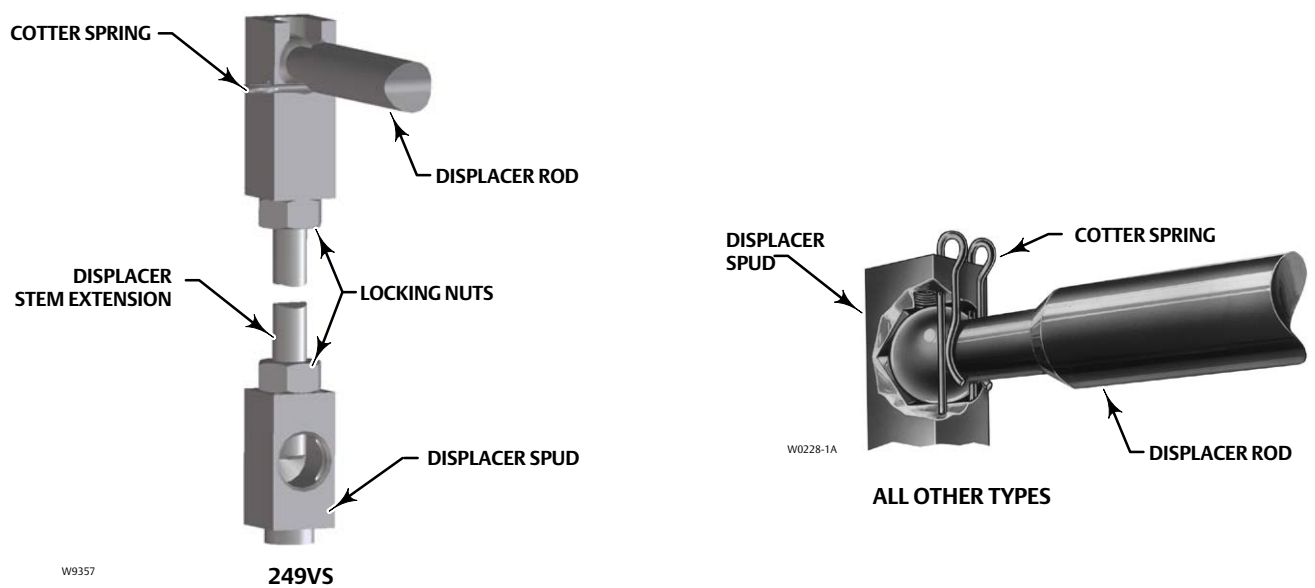

Figure 8. Displacer and Displacer Rod Connections



Top-Mounted Sensor

CAUTION

If inserting the displacer into the vessel before attaching to the displacer rod, provide a means of supporting the displacer to prevent it from dropping into the vessel and suffering damage.

Figure 7 shows an example of a top-mounted cageless sensor. You may attach the displacer to the displacer rod before installing the sensor on the vessel. If the displacer diameter is small enough, you may install a long or sectionalized displacer through the sensor head access hole after the sensor is installed on the vessel. Connect the displacer as shown in figure 8, locking the assembly with the cotter springs provided. If a stem extension is used between the displacer spud and the stem end piece, make sure the nuts are tight at each end of the stem. Install and tighten suitable cap screws in the flanged connection to complete the installation.

A special travel stop may be provided on top-mounted sensors to aid in servicing of the sensor. This option prevents dropping the displacer and stem when the displacer rod is disconnected.

Supply and Output Pressure Connections

⚠ WARNING

To avoid personal injury or property damage resulting from the sudden release of pressure, do not install any system component where service conditions could exceed the limits given in this manual. Use pressure-relieving devices as required by government or accepted industry codes and good engineering practices.

CAUTION

Do not use sealing tape on pneumatic connections. This instrument contains small passages that may become obstructed by detached sealing tape. Thread sealant paste should be used to seal and lubricate pneumatic threaded connections.

Figure 9 shows dimensions, locations, and connections for controller/transmitter installation. All pressure connections to the controller/transmitter are 1/4 NPT internal.

Supply Pressure

⚠ WARNING

Personal injury or property damage may occur from an uncontrolled process if the supply medium is not clean, dry, oil-free air, or noncorrosive gas. While use and regular maintenance of a filter that removes particles larger than 40 micrometers in diameter will suffice in most applications, check with an Emerson Automation Solutions field office and industry instrument air quality standards for use with corrosive air or if you are unsure about the proper amount or method of air filtration or filter maintenance.

Supply pressure medium must be clean, dry, and noncorrosive and meet the requirements of ISA Standard 7.0.01 or ISO 8573-1. A maximum 40 micrometer particle size in the air system is acceptable. Further filtration down to 5

micrometer particle size is recommended. Lubricant content is not to exceed 1 ppm weight (w/w) or volume (v/v) basis. Condensation in the air supply should be minimized.

Figure 9. Controller/Transmitter Dimensions and Connections

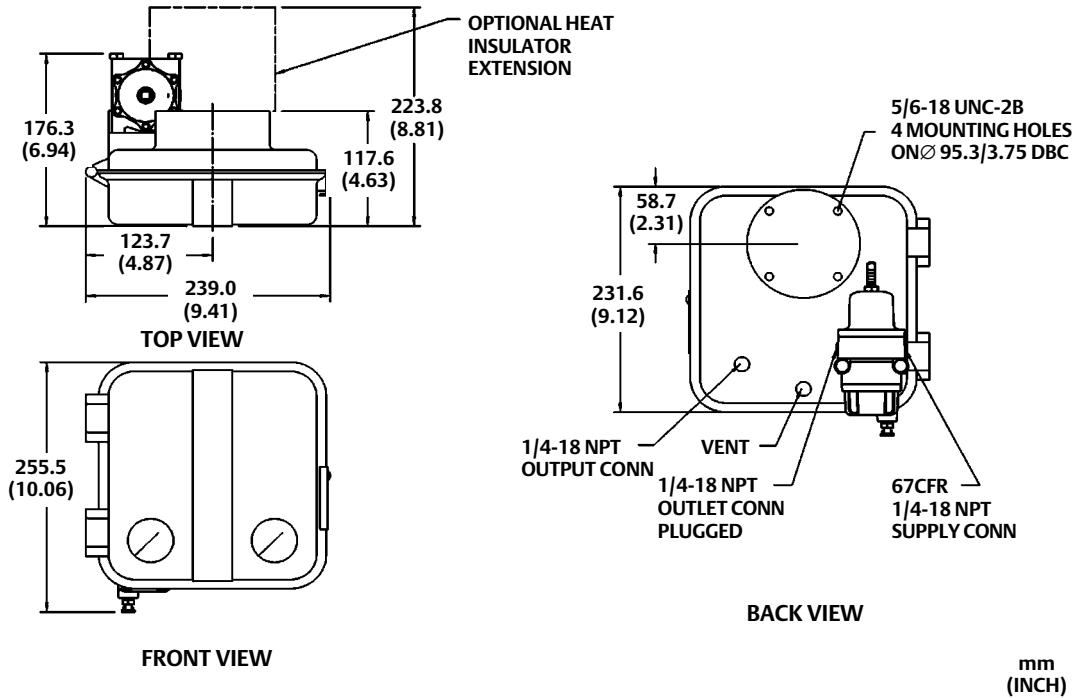

Use a suitable supply pressure regulator to reduce the supply pressure to the normal operating supply pressure shown in table 3. As shown in figure 9, a 67CFR filter/regulator mounts on the back of the controller/transmitter case and mates with the supply pressure connection on the controller/transmitter case. Pipe the supply pressure to the IN connection of the regulator. Typically, the 67CFR filter/regulator accepts supply pressures between 2.5 and 17 bar (35 and 250 psig). For specific regulator limits, refer to the appropriate regulator instruction manual.

If operating the controller or transmitter from a high pressure source [up to 138 bar (2000 psig)], use a high pressure regulator system, such as the 1367 High Pressure Instrument Supply System. For 1367 system installation, adjustment, and maintenance information, see the separate instruction manual.

Controller/Transmitter Output Connection

As shown in figure 9, the output pressure connection is on the back of the controller/transmitter case. After connecting the output pressure line, turn on the supply pressure, adjust the filter/regulator to the appropriate supply pressure required for the controller/transmitter and check all connections for leaks.

Vent Assembly

⚠ WARNING

Personal injury or property damage could result from fire or explosion of accumulated gas, or from contact with hazardous gas, if a flammable or hazardous gas is used as the supply pressure medium. Because the instrument case and cover

assembly do not form a gas-tight seal when the assembly is enclosed, a remote vent line, adequate ventilation, and necessary safety measures should be used to prevent the accumulation of flammable or hazardous gas. However, a remote vent pipe alone cannot be relied upon to remove all flammable and hazardous gas. Vent line piping should comply with local and regional codes, and should be as short as possible with adequate inside diameter and few bends to reduce case pressure buildup.

CAUTION

When installing a remote vent pipe, take care not to overtighten the pipe in the vent connection. Excessive torque will damage the threads in the connection.

The vent assembly (see figure 9) or the end of a remote vent pipe must be protected against the entrance of all foreign matter that could plug the vent. Use 13 mm (1/2-inch) pipe for the remote vent pipe, if one is required. Check the vent periodically to be certain it has not become plugged.

Prestartup Checks

Adjustments are shown in figure 10 unless otherwise indicated. Open-loop conditions must exist when performing the prestartup checks. To obtain open-loop conditions:

- make sure there is no process flow through the final control element, or
- disconnect the controller/transmitter output signal line and connect it to a pressure gauge.

During prestartup, the displacer must be positioned from its maximum to its minimum range of operation. Provide a means to change the process variable (the process level or interface). If the process variable cannot be varied sufficiently, use the precalibration procedures in the Calibration section to simulate the process variable changes required for these checks.

Make sure the RAISE LEVEL dial on the controller is mounted with the correct side facing out. The dial is marked on both sides with an arrow. The arrow points to the left on one side and to the right on the other. When the sensor is mounted to the left of the controller/transmitter, the arrow on the raise level dial should point to the left, as shown in figure 10. If the sensor is to the right, the arrow should point to the right. If necessary, remove the two mounting screws, turn the dial over so the arrow points correctly, and reinstall the mounting screws. The level directions shown on the dial will be correct for both direct-acting and reverse-acting controllers. For a transmitter, use the same side of the ZERO ADJUSTMENT dial for both right- and left-hand sensor mountings.

On a controller or transmitter with an optional mechanical indicator assembly, the travel indicator plate is also marked with an arrow on both sides. If the sensor is to the left of the controller/transmitter, the arrow on the plate should point to the left. If the sensor is to the right, the arrow should point to the right. If necessary, reinstall the plate so that the arrow points in the correct direction.

Figure 10. Adjustment Locations

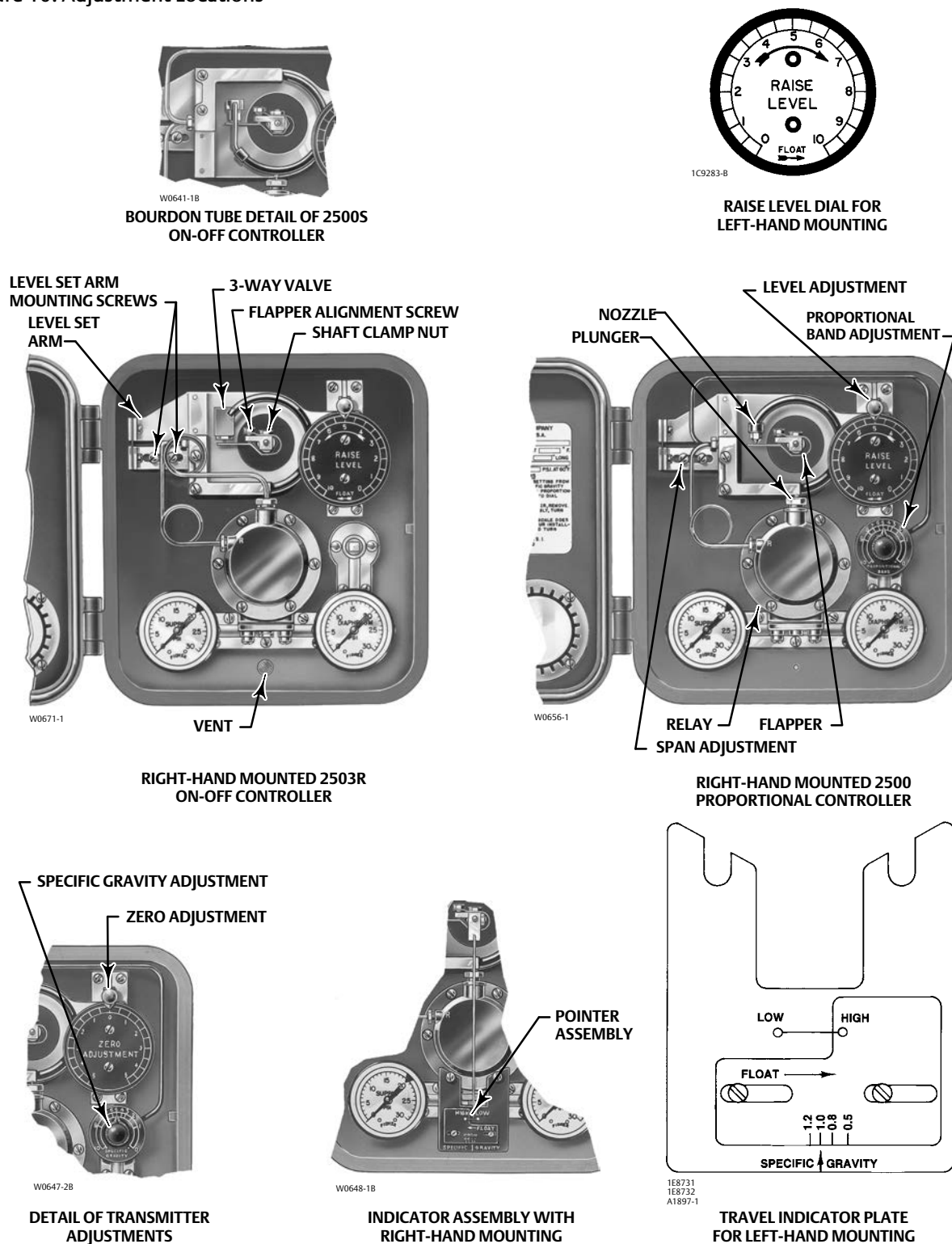

Set the PROPORTIONAL BAND control on a 2500 or 2500S controller, or the SPECIFIC GRAVITY control on a 2500T transmitter, as follows:

- **Sensor with Both Standard Torque Tube and Standard Volume Displacer**—If the torque tube is standard and the displacer volume is close to that listed in table 2, use figure 11 to find the PROPORTIONAL BAND or SPECIFIC GRAVITY setting. Locate the specific gravity of the process fluid on fluid level applications, or the difference between minimum and maximum specific gravity on interface level or density applications, on the vertical axis of the chart. From this location, trace horizontally to the curve with the desired percentage of displacer used, then trace vertically up or down to determine the proper dial setting on the horizontal axis.

Figure 11. Proportional Band and Specific Gravity Setting Chart (chart assumes standard wall torque tube and displacer volume in table 2)

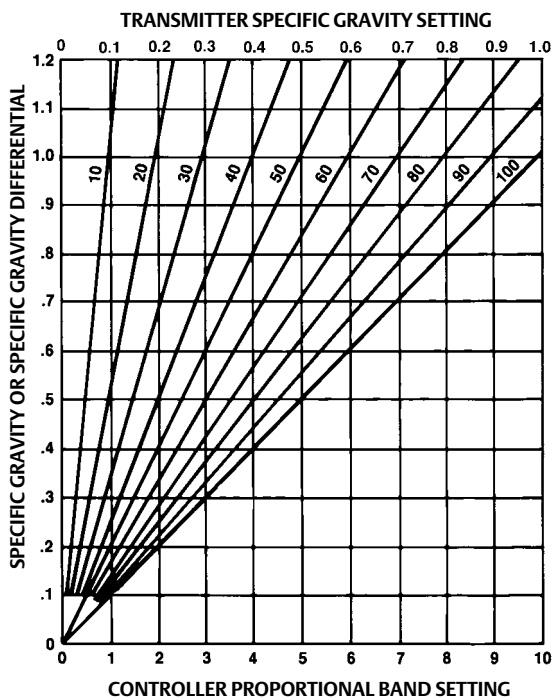

NOTE:
EACH CURVE MARKED WITH PERCENTAGE OF DISPLACER USED.
1C9259-G
A3891-1

- **Sensor with Nonstandard Torque Tube and/or Displacer with Other than Standard Volume**—If the construction does not have a standard wall torque tube or has a displacer volume that deviates significantly from the volume listed in table 2, or both, the PROPORTIONAL BAND or SPECIFIC GRAVITY dial setting does not necessarily indicate the actual proportional band or specific gravity. To determine the correct dial setting, solve the following equation:

$$\text{Corrected Dial Setting Required} = \left(\frac{L}{100}\right)(\text{SP GR})\left(\frac{V_a}{V_r}\right)(X)$$

where:

L = percentage of displacer length desired for full output pressure change (e.g., if 80% of displacer is used, L = 80)

SP GR = specific gravity of the process fluid (for interface level control, use the difference between the specific gravity of the two fluids; for specific gravity control, use the difference between the upper and lower range limits of specific gravity).

V_a = actual displacer volume, cubic inches listed on the sensor nameplate.

V_r = standard displacer volume, cubic inches, from table 2.

X = torque tube factor (1.0 for standard torque tubes, 2.0 for thin-wall torque tubes, or 0.5 for heavy-wall torque tubes).

2500 Controller or 2500T Transmitter

Note

In the following steps the output pressure can go as high as the controller supply pressure.

1. Turn on the supply pressure and check that the supply pressure gauge reads 1.4 bar (20 psig) for a 0.2 to 1 bar (3 to 15 psig) or 2.4 bar (35 psig) for a 0.4 to 2 bar (6 to 30 psig) output pressure range. If the pressure is incorrect, loosen the locknut of the 67CFR filter/regulator (figure 9); turn the adjusting screw clockwise to increase the pressure or, counterclockwise to decrease the pressure. Tighten the locknut after setting the regulator pressure.
2. Set the process variable to its minimum value.
3. Make sure that the PROPORTIONAL BAND or SPECIFIC GRAVITY control is at the setting determined earlier in this section. Then, set the RAISE LEVEL or ZERO ADJUSTMENT control at an appropriate value according to table 5. This table gives recommended settings based on maximum and minimum possible PROPORTIONAL BAND and SPECIFIC GRAVITY settings. If an intermediate PROPORTIONAL BAND or SPECIFIC GRAVITY setting is necessary, extrapolation may be used to determine an appropriate RAISE LEVEL or ZERO ADJUSTMENT setting.

Note

The raise level dial does not reflect actual fluid level in the tank or fluid level position on the displacer.

4. The OUTPUT gauge on a 0.2 to 1 bar (3 to 15 psig) range should read 0.2 bar (3 psig) for direct or 1 bar (15 psig) for reverse action. On a 0.4 to 2 bar (6 to 30 psig) range the OUTPUT gauge should read 0.4 bar (6 psig) for direct or 2 bar (30 psig) for reverse action.
5. On a controller or transmitter with a mechanical indicator assembly, the pointer should be over the LOW point on the indicator plate. If a slight adjustment is necessary, loosen the side hex clamp nut (key 40, figure 16), shift the pointer, and retighten the nut.
6. Increase the process variable to the level desired for full output change. The OUTPUT gauge on a 0.2 to 1 bar (3 to 15 psig) range should read 1 bar (15 psig) for direct or 0.2 bar (3 psig) for reverse action. On a 0.4 to 2 bar (6 to 30 psig) range the OUTPUT gauge should read 2 bar (30 psig) for direct or 0.4 bar (6 psig) for reverse action. On a controller or transmitter with an indicator assembly, the pointer should be over the HIGH point on the indicator plate; slight plate adjustment may be necessary, as described at the end of step 5.
7. If all prestartup checks are satisfactory, go to the startup procedure. If performance is unsatisfactory, proceed to the Calibration section.

2500S Controller

Note

In the following steps the output pressure can go as high as the controller supply pressure.

1. Turn on the supply pressure and check that the SUPPLY pressure gauge reads 1.4 bar (20 psig) for a 0 to 1.4 bar (0 to 20 psig) output pressure range or 2.4 bar (35 psig) for a 0 to 2.4 bar (0 to 35 psig) output pressure range. If the pressure is incorrect, loosen the locknut of the 67CFR filter/regulator (figure 9); turn the adjusting screw clockwise to increase the pressure or counterclockwise to decrease pressure. Tighten the locknut after setting the pressure.
 2. Set the process variable to its minimum value.
 3. On a controller with a mechanical indicator assembly, the pointer should be over the LOW point on the indicator plate. If a slight adjustment is necessary, loosen the hex clamp nut (key 40, figure 16), shift the pointer and retighten the nut.
-

Note

Adjustment of the RAISE LEVEL control can set the switching points anywhere within the length of the displacer. Be careful not to set the switching points so that one is off the displacer.

4. Make sure that the PROPORTIONAL BAND control is at the setting determined in the previous procedures. Set the RAISE LEVEL control to 0, then set it to 1.0 for a direct-acting or 4.0 for a reverse-acting controller.
 5. The OUTPUT gauge should read 0 bar (0 psig) for direct or supply pressure for reverse action.
 6. Increase the process variable until the OUTPUT gauge changes to either supply pressure for direct or 0 bar (0 psig) for reverse acting. The process variable should be at the desired high trip value. On a controller with an indicator assembly, the pointer should be over the HIGH point on the indicator plate; slight adjustment may be necessary, as described at the end of step 3.
 7. Decrease the process variable until the OUTPUT gauge changes to 0 bar (0 psig) for direct or supply pressure for reverse action (depending on controller range). The process variable should be at the desired low trip value.
 8. If all prestartup checks are satisfactory, proceed to the Startup section. If performance is unsatisfactory, proceed to the Calibration section.
-

2503 Controller

Note

In the following steps the output pressure can go as high as the controller supply pressure.

Note

Since the 2503 controller has no proportional valve, the differential gap between switching points is adjusted by varying the supply pressure. This gap can be varied from approximately a 89 mm (3.5 inch) level change at 1 bar (15 psig) to a 152 mm (6.0 inch) level change at 1.7 bar (25 psig) with a standard volume displacer and a fluid with a specific gravity of 1.0. The gap also varies inversely according to density; a fluid with 0.8 specific gravity produces a 112 mm (4.4 inch) level change at 1 bar (15 psig) to a

191 mm (7.5 inch) change at 1.7 bar (25 psig). Set the gap at a pressure low enough to be compatible with the limitations of the diaphragm control valve or other final control element.

1. Turn on the supply pressure. If necessary, adjust the 67CFR regulator to produce the desired differential gap by loosening the locknut (figure 9) and turning the adjusting screw clockwise to increase or counterclockwise to decrease pressure. Tighten the locknut.
2. Locate the process variable at its minimum value.

Note

Adjustment of the RAISE LEVEL control can set the switching points anywhere within the length of the displacer. Be careful not to set the switching points so that one is off the displacer.

3. Set the RAISE LEVEL control to 0 and then reset it as follows:
 - a. For direct-acting controllers, set it between 1.0 and 1.5.
 - b. For reverse-acting controllers, set it between 3.5 and 4.0.
4. The OUTPUT gauge should read 0 bar (0 psig) for direct or full supply pressure for reverse action.
5. Increase the process variable until the OUTPUT gauge changes to full supply pressure for direct or 0 bar (0 psig) for reverse action. The process variable should be at the desired high trip value.
6. Decrease the process variable until the OUTPUT gauge changes to 0 bar (0 psig) for direct or full supply pressure for reverse action. The process variable should be at the desired low trip value.
7. If all prestartup checks are satisfactory, proceed to the Startup section. If performance is unsatisfactory, proceed to the Calibration section.

Adjustments

This section explains controller/transmitter action and adjustments. Figure 10 shows adjustment locations.

Control Action

The following is a definition of control action.

- **Direct Action**—Increasing fluid level, interface level, or density, increases the output signal.
- **Reverse Action**—Increasing fluid level, interface level, or density, decreases the output signal.
Controller/transmitters factory-set for reverse-acting have the suffix letter R added to their type number.

The control action is determined by the cage head mounting position and by the Bourdon tube-flapper arrangement in the controller/transmitter. Refer to figure 4 for mounting positions and to figure 15 for Bourdon tube-flapper arrangements. To change the action, refer to the changing action procedure in the Maintenance section.

Level Adjustment (Controllers Only)

To make a level adjustment, open the controller cover, loosen the knurled adjustment screw, and rotate the adjustment lever around the RAISE LEVEL dial. To raise the fluid or interface level, or increase density, rotate this knob

in the direction of the arrows. To lower the level or decrease density, rotate the knob in the opposite direction. This procedure is the same for either direct or reverse action. Tighten the knurled screw.

Note

The RAISE LEVEL dial does not reflect actual fluid level in the tank or fluid level position on the displacer.

Zero Adjustment (Transmitters Only)

To make a zero adjustment, open the transmitter cover, loosen the adjustment screw and rotate the adjustment lever around the ZERO ADJUSTMENT dial. This adjustment sets the output pressure to correspond to a specific level on the displacer. Tighten the knurled screw.

Proportional Band Adjustment (Except Transmitters and 2503 Controllers)

The proportional band adjustment varies the amount of process variable change required to obtain a full output pressure change. To perform this adjustment, open the controller cover and turn the PROPORTIONAL BAND adjustment (see figure 10). Refer to the prestartup check procedures to determine the proper setting.

Specific Gravity Adjustment (Transmitters Only)

This adjustment also varies the amount of process variable change required to obtain a full output pressure change. To perform this adjustment, open the transmitter cover and turn the SPECIFIC GRAVITY adjustment (see figure 10). Refer to the prestartup check procedures to determine the proper setting.

Calibration

Precalibration Requirements

The controller/transmitter can be calibrated in the field, mounted on the vessel containing the process fluid. It may also be done in the shop, but other means of obtaining a displacement force change must be provided. There are wet and dry methods of adapting the calibrating procedure.

Note

Contact your [Emerson sales office](#) for information on obtaining Simulation of Process Conditions for Calibration of Fisher Level Controllers and Transmitters—Supplement to 249 Sensor Instruction Manuals ([D103066X012](#)).

Wet Calibration

Remove the entire controller/transmitter and sensor assembly from the vessel. For caged sensors, pour the fluid into the cage. For cageless sensors, suspend the displacer to an appropriate depth in a fluid having a specific gravity equal to that of the process fluid.

If necessary, you may use water for wet calibration in the shop. You must compensate for the difference between the specific gravities of water and the process fluid, however. As an example, assume the process fluid has a specific gravity of 0.7. The specific gravity of water is 1.0. To simulate a process level of 50 percent of the input span, would require a water level of 35 percent ($0.7/1.0 \times 50$ percent = 35 percent).

Dry Calibration

Remove the controller/transmitter and torque tube arm, as a single unit, from the cage or vessel. Then, wherever the standard calibration procedures in this manual require a specific process variable input to the sensor, simulate the process variable by suspending the proper weight (such as a can of sand) from the end of the displacer rod. Complete the following procedures (Controller/Transmitter and Torque Tube Arm Disassembly) and (Determining the Amount of Suspended Weight) before proceeding to the Calibrating Procedure.

Controller/Transmitter and Torque Tube Arm Disassembly

⚠ WARNING

To avoid personal injury from contact with the process fluid, lower the vessel level below the sensor torque tube arm, or shut off the cage equalizing valves and drain the cage before proceeding. For closed vessels, release any pressure that may be in the vessel before removing the sensor assembly.

When removing the displacer from the displacer rod or removing the controller/transmitter and torque tube arm from the cage or vessel, refer to the appropriate 249 instruction manual for assistance. The method of removing the displacer or torque tube arm and attached controller/transmitter varies with the type of sensor.

For a caged sensor with top equalizing connection, it may be appropriate to remove the entire cage from the vessel before disassembling.

CAUTION

If the displacer is to be disconnected from the displacer rod before the sensor assembly is removed from the cage or vessel, provide a means of supporting the displacer to prevent it from dropping and suffering damage. The spuds or stem end pieces on all displacers have holes suitable for inserting rods or other supports.

Additionally, a threaded rod may be installed into the 1/4-inch 28 UNF threaded hole in the displacer spud or stem end piece of top-mounted cageless and all caged sensors. For some top-mounted sensors with long displacers, the sensor may be removed through the access hole in the sensor head.

For 249BP sensors with travel stop, the stem end piece pins will secure the displacer on the travel stop as long as the travel stop plate is installed and the sensor head is in position.

Determining the Amount of Suspended Weight

CAUTION

Avoid overloading a torque tube sized for interface or density applications. Consult your [Emerson sales office](#) or Local Business Partner for the maximum allowable substitute weight, W_s , that may be used with your particular construction.

To determine the total weight that must be suspended from the displacer rod to simulate a certain condition of fluid level or specific gravity, solve the following equation:

$$W_s = W_d - [(0.0361)(V)(SP GR)]$$

where:

W_s = Total suspended weight in pounds (should never be less than 0.5 pounds). For a unit with a horizontal displacer, make sure the center of gravity of the substitute weight is where it would be on the actual displacer.

Note

For liquid level control only, simulate the lower range limit of the input span by suspending the displacer from the displacer rod. For other values of input span, remove the displacer and suspend the appropriate weight as determined in the equation above.

W_d = Weight of the displacer, in pounds (determine by weighing displacer).

0.0361 = Weight of one cubic inch of water (specific gravity = 1.0), in pounds.

V = Volume, in cubic inches, of the portion of the displacer submerged. Or,

$$V = (\pi/4) (\text{displacer diameter})^2 (\text{length of displacer submerged})$$

SP GR = Specific gravity of the process fluid at operating temperature.

For interface level measurement, the equation becomes:

$$W_s = W_d - [(0.0361)(V_t)(SP GR_l) + (0.0361)(V_h)(SP GR_h - SP GR_l)]$$

where:

V_t = Total volume, in cubic inches, of the displacer.

SP GR_l = Specific gravity of the lighter of the fluids at operating temperature.

V_h = Volume, in cubic inches, of the portion of the displacer submerged in the heavier of the fluids.

Or,

$$V = (\pi/4) (\text{displacer diameter})^2 (\text{length of the displacer submerged})$$

SP GR_h = Specific gravity of the heavier of the fluids at operating temperature.

Calibration Procedure

⚠ WARNING

The following calibration procedures require taking the controller/ transmitter out of service. To avoid personal injury and property damage caused by an uncontrolled process, provide some temporary means of control for the process before taking the controller/transmitter out of service.

Figure 10 shows adjustment locations, except as otherwise indicated. In order to calibrate, open-loop conditions must exist. One way to obtain an open loop is to ensure that there is no flow through the final control element. Another way to obtain an open loop is to disconnect the controller/transmitter output signal line and plug the output connection with a test pressure gauge.

Several steps in these calibrating procedures require setting the process variable at its minimum and maximum limits, according to table 6.

Note

If the process cannot be varied readily or the Wet Calibration method cannot be used in the following steps, be sure to use the proper sequence of correct weights as found in the Determining Amount of Suspended Weight procedure. Whenever the following steps require particular prestartup checks, refer to the appropriate procedures for: 2500 Controller or 2500T Transmitter, 2500S Controller, or 2503 Controller.

2500 Controller and 2500T Transmitter

1. Turn on the supply pressure and check that it is set according to the appropriate prestartup checks procedure.
2. Make sure that the PROPORTIONAL BAND or SPECIFIC GRAVITY adjustment is at the setting determined according to the appropriate prestartup check procedure.
3. Adjust the RAISE LEVEL (2500) or ZERO ADJUSTMENT (2500T) to the appropriate value per table 5. This table gives recommended settings based on maximum and minimum possible PROPORTIONAL BAND (2500) or SPECIFIC GRAVITY (2500T) settings. If an intermediate PROPORTIONAL BAND or SPECIFIC GRAVITY setting is necessary, extrapolation may be used to determine a new RAISE LEVEL or SPECIFIC GRAVITY setting.

Table 5. Recommended Settings For Pre-Startup Checks

MOUNTING	ACTION	RECOMMENDED RAISE LEVEL SETTING FOR 2500 CONTROLLER		RECOMMENDED ZERO ADJUSTMENT SETTING FOR 2500T TRANSMITTER	
		For Predetermined PROPORTIONAL BAND Dial Setting of 10 ⁽¹⁾	For Predetermined PROPORTIONAL BAND Dial Setting of 0 ⁽¹⁾	For Predetermined SPECIFIC GRAVITY Dial Setting of 1.0 ⁽¹⁾	For Predetermined SPECIFIC GRAVITY Dial Setting of 0 ⁽¹⁾
Right-hand	Direct	3.0 to 3.5	4.0 to 4.5	1.5 to 2.0 to right	0.5 to 1.0 to right
	Reverse	6.5 to 7.0	0.5 to 1.0	1.5 to 2.0 to left	4.0 to 4.5 to right
Left-hand	Direct	3.0 to 3.5	4.0 to 4.5	1.5 to 2.0 to left	0.5 to 1.0 to left
	Reverse	6.5 to 7.0	0.5 to 1.0	1.5 to 2.0 to right	4.0 to 4.5 to left

1. For proportional band dial settings between 10 and 0 or for specific gravity dial settings between 1.0 and 0, interpolate the value.

4. Set the process variable to the minimum value of the input range as shown in table 6. For constructions with an indicator assembly, make sure that the pointer is over the LOW mark.

Note

In the following step, the alignment screw (key 33, figure 16) must always remain screwed in far enough to provide spring tension on the underside of the alignment screw head.

5. Adjust the flapper (key 32, figure 16) to obtain the appropriate pressure listed below. For coarse flapper adjustment, loosen the hex nut (key 40, figure 16) and rotate the flapper assembly about the torque tube shaft. For fine flapper adjustment, turn the flapper alignment screw (key 33, figure 16).

- For Direct Acting 2500, 2500T, 0.2 bar (3 psig) for a 0.2 to 1.0 bar (3 to 15 psig) output or 0.4 bar (6 psig) for a 0.4 to 2.0 bar (6 to 30 psig) output.
 - For Reverse Acting 2500, 2500T, 1.0 bar (15 psig) for a 0.2 to 1.0 bar (3 to 15 psig) output or 2.0 bar (30 psig) for a 0.4 to 2.0 bar (6 to 30 psig) output.
6. Visually examine the nozzle and flapper to ensure the nozzle is as square as possible with the flapper. The nozzle can be realigned by loosening the Bourdon tube mounting screws (key 45, figure 16) and rotating the Bourdon tube slightly. If the nozzle is realigned, tighten the mounting screws and repeat step 5.
 7. Set the process variable to the maximum value of the input range as shown in table 6.

Table 6. Minimum and Maximum Limits for Setting Process Variables

Application	Minimum Limit	Maximum Limit
Liquid Level	Displacer must be completely out of liquid	Displacer must be completely submerged in liquid
Interface	Displacer must be completely submerged in lighter of two process liquids	Displacer must be completely submerged in heavier of two process liquids
Density	Displacer must be completely submerged in liquid having specific gravity of lowest range point	Displacer must be completely submerged in liquid having specific gravity of highest range point

8. The output pressure should be:
 - For Direct Acting 2500, 2500T, 1.0 bar (15 psig) for a 0.2 to 1.0 bar (3 to 15 psig) output or 2.0 bar (30 psig) for a 0.4 to 2.0 bar (6 to 30 psig) output.
 - For Reverse Acting 2500, 2500T, 0.2 bar (3 psig) for a 0.2 to 1.0 bar (3 to 15 psig) output or 0.4 bar (6 psig) for a 0.4 to 2.0 bar (6 to 30 psig) output.
9. If the output pressure agrees with that shown in step 8, proceed to step 10. If the output pressure does not agree, go to step 11.
10. If the unit does not contain an indicator assembly, go to the Startup section. If the unit contains an indicator assembly, change the pointer span by loosening the indicator plate screws (key 41, figure 16, detail of indicator assembly), slide the plate until the HIGH mark is under the pointer. Tighten the plate screws and go to the Startup section.

Note

Any sliding of the level set arm (key 28, figure 16) in the following step changes the zero as well as the output pressure span.

11. To adjust the output pressure span, loosen the two level set mounting screws (see figure 16) and slide the flexure strip base (key 27) right or left along the elongated slotted hole as follows:
 - To increase the output pressure span, slide the flexure strip base away from the torque tube shaft.
 - To decrease the output pressure span, slide the flexure strip base toward the torque tube shaft.

Retighten the screws. If the flexure strip base has been moved as far as possible and the output pressure span is still too large or too small, proceed to step 13.

12. Repeat the procedure from step 4 until the required calibration points are obtained.

Note

Any change of the PROPORTIONAL BAND or SPECIFIC GRAVITY adjustment in the following step changes the zero as well as the output pressure span.

13. If the flexure strip base has been moved as far as possible and the output pressure span is still too large or too small, slightly adjust the PROPORTIONAL BAND or SPECIFIC GRAVITY adjustment as follows:
 - If the output pressure span is too large, slightly increase the PROPORTIONAL BAND or SPECIFIC GRAVITY setting.
 - If the output pressure span is too small, slightly decrease the PROPORTIONAL BAND or SPECIFIC GRAVITY setting.
14. Repeat the procedure from step 4 until the required calibration points are obtained.

Note

If you cannot calibrate the controller or transmitter, look for other problems as described in the Troubleshooting procedures, such as leaking connections, or a binding displacer rod. If none of these troubles are apparent, ensure that the displacer is sized correctly for the application.

2500S and 2503 Controllers

1. Turn on the supply pressure and check that it is set according to the appropriate prestartup checks procedure.
2. Make sure that the PROPORTIONAL BAND adjustment (2500S only) is at the setting determined according to the appropriate prestartup check procedure.
3. Perform one or the other of the following:
 - For direct acting controllers, set the RAISE LEVEL adjustment between 1.0 and 1.5.
 - For reverse acting controllers, set the RAISE LEVEL adjustment between 3.5 and 4.0.
4. Set the process variable at the minimum value of the input range as shown in table 6. For constructions with an indicator assembly, make sure that the pointer is over the LOW mark.

Note

In the following step, the alignment screw (key 33, figure 16) must always remain screwed in far enough to provide spring tension on the underside of the alignment screw head.

5. Be sure the flapper is centered over the nozzle. If not, loosen the hex nut (key 40, figure 16) and reposition the flapper, tighten the hex nut.
6. Adjust the flapper (key 32, figure 16) as described below. For coarse flapper adjustment, loosen the hex nut (key 40, figure 16) and rotate the flapper assembly about the torque tube shaft. For fine flapper adjustment, turn the flapper alignment screw (key 33, figure 16).
 - For Direct Acting Controllers, move the flapper toward the nozzle until the output pressure switches to full supply pressure, then carefully adjust the flapper away from the nozzle until the output pressure switches to 0 bar (0 psig).
 - For Reverse Acting Controllers, move the flapper away from the nozzle until the output pressure switches to 0 bar (0 psig), then carefully adjust the flapper toward the nozzle until the output pressure switches to full supply pressure.

7. Slowly increase the process variable until the output pressure switches:
 - For Direct Acting Controllers, slowly increase the process variable until the output pressure switches to full supply pressure. The process variable should be at the maximum value of input range as shown in table 6. If the process variable agrees with table 6, proceed with step 8. If the process variable does not agree with table 6, proceed to step 9.
 - For Reverse Acting Controllers, slowly increase the process variable until the output pressure switches to 0 bar (0 psig). The process variable should be at the maximum value of input range as shown in table 6. If the process variable agrees with table 6, proceed with step 8. If the process variable does not agree with table 6, proceed to step 9.
 8. If the unit does not contain an indicator assembly, go to the startup section. If the unit contains an indicator assembly, change the pointer span by loosening the indicator plate screws (key 41, figure 16, indicator assembly detail), slide the plate until the HIGH mark is under the pointer. Tighten the plate screws and go to the startup section.
-

Note

Any sliding of the level set arm (key 28, figure 16) in the following step changes the zero as well as the differential gap.

9. To adjust the differential gap, loosen the two level set mounting screws (see figure 16) and slide the flexure strip base (key 27) right or left along the elongated slotted hole as follows:
 - To decrease the differential gap, slide the flexure strip base away from the torque tube shaft.
 - To increase the differential gap, slide the flexure strip base toward the torque tube shaft.

Retighten the screws. For the 2500S only, if the flexure strip base has been moved as far as possible and the differential gap is still too low, proceed to step 11.

10. Repeat the procedure from step 4 until the required calibration points are obtained.
-

Note

Any change in the PROPORTIONAL BAND adjustment in the following step changes the zero as well as the differential gap.

11. If the flexure strip base has been moved as far as possible and the differential gap is still too large or too small, adjust the PROPORTIONAL BAND as follows:
 - If the differential gap is too large, slightly decrease the PROPORTIONAL BAND setting.
 - If the differential gap is too small, slightly increase the PROPORTIONAL BAND setting.
 12. Repeat the procedure from step 4 until the required calibration points are obtained.
-

Note

If you cannot calibrate the controller, look for other problems as described in the Troubleshooting procedures, such as a nozzle that is not perpendicular to the flapper, leaky connections, or a binding displacer rod. If none of these troubles are apparent, ensure the displacer is sized correctly for the application.

Startup

Adjustment locations are shown in figure 10. The pre-startup or calibration procedures must be completed prior to startup.

2500 Controller

1. Slowly open the upstream and downstream manual control valves in the pipeline. If the pipeline has a bypass valve, close the valve.
2. If desired, adjust the proportional band to the narrowest (lowest) setting that maintains stable control. Proportional band adjustments will affect the process level and may require a level adjustment. If adjusting proportional band, make the adjustments in small increments.
3. To confirm the optimum proportional band setting, momentarily create a load upset. If cycling occurs, broaden (increase) the proportional band until process oscillations diminish rapidly. In general, the narrowest proportional band that does not produce cycling provides the best control.

2500T Transmitter

1. Make sure that the SPECIFIC GRAVITY and ZERO ADJUSTMENT controls are set according to the 2500 Controller or 2500T Transmitter portion of the pre-startup checks procedures.
2. Slowly open the upstream and downstream manual control valves in the pipeline. If the pipeline has a manual bypass valve, close the valve.

2500S Controller

1. Set the switching points according to the 2500S Controller portion of the prestartup checks procedures.
2. Slowly open the upstream and downstream manual control valves in the pipeline. If the pipeline has a manual bypass valve, close the valve.
3. If necessary, the proportional band may be adjusted to increase or decrease the differential gap. Adjust the RAISE LEVEL adjustment to reposition the differential gap. After readjustment, confirm the controller is still switching correctly at both switching points.

2503 Controller

1. Set the switching points according to the 2503 Controller portion of the prestartup checks procedures.
2. Slowly open the upstream and downstream manual control valves in the pipeline. If the pipeline has a manual bypass valve, close the valve.
3. If necessary, reposition the switching points by adjusting the RAISE LEVEL control. For example, if the differential gap is set for 102 mm (4-inches) of level change, this 102 mm (4-inches) can be set anywhere within the length of the displacer. After readjustment, confirm the controller is still switching correctly at both switching points.

Principle of Operation

The controller/transmitter receives the change in fluid level, fluid-to-fluid interface level, or density from the change in the buoyant force the fluid exerts on the sensor displacer. The displacer, through a mechanical linkage, imparts a rotary motion to the torque tube shaft. This rotary motion positions the flapper according to the level position of the displacer; the nozzle/Bourdon tube arrangement sends a pneumatic signal to the relay valve.

All 2500 and 2503 controller/transmitters use the same basic pressure-balanced relay assembly. The following descriptions explain how the relay action produces the output signal with the various controller/transmitter constructions.

2500 Controller or 2500T Transmitter

Full supply pressure comes to the relay from the regulator, as shown in figure 12. The relay has a fixed restriction through which supply pressure bleeds before entering the large diaphragm area and the inner Bourdon tube channel. In a steady-state condition, the process level holds the torque tube and attached flapper steady in relation to the nozzle. This allows pressure to escape between the nozzle and flapper at the same rate it bleeds into the large diaphragm area. The large diaphragm holds the inlet end of the relay valve slightly open to compensate for the venting of output pressure through the proportional valve as it maintains a steady-state position of the final control element. The output pressure, through the three-way proportional valve, affects the Bourdon tube outer channel, holding the Bourdon tube in a steady-state position.

A process level change raises or lowers the displacer, moving the flapper with respect to the nozzle. If the process level change increases nozzle pressure, the large diaphragm moves down; this closes the exhaust end and opens the inlet end of the relay valve (see figure 12). This action of the relay valve increases the output pressure to the final control element. Since the area ratio of the large diaphragm to the small diaphragm is three-to-one, the small diaphragm action amplifies the output pressure change. The three-way proportional valve lets the increase in output pressure apply to the Bourdon tube outer channel. The expansion of the Bourdon tube moves the nozzle away from the flapper slowing the response of the pneumatic circuit.

If the process level change decreases the nozzle pressure, the large diaphragm moves up. This action closes the inlet end and opens the exhaust end of the relay valve which allows output pressure to exhaust. This relay valve action reduces the output pressure to the final control element and is the reverse of the previous explanation.

The proportional valve varies the reaction of the Bourdon tube to changes in the output pressure. For additional information on the proportional valve action, refer to the following proportional valve subsection.

Proportional Valve

The three-way proportional valve is adjustable to allow some or all of the output pressure change to feed back to the Bourdon tube outer channel, providing proportional band control (see figure 12). The Bourdon tube moves to counteract the pressure changes in the nozzle, equaling the relay diaphragm pressure differential. The relay valve maintains a new output pressure according to the change in the process variable.

A wide-open proportional valve (fully counterclockwise) permits feedback of the output pressure signal change and produces 100 percent proportional response. A closed (fully clockwise) proportional valve produces smaller proportional responses, because part of the output pressure change vents through the proportional valve exhaust.

2500S Controller

This construction has the same flapper, relay, and proportional valve as the 2500 controller. However, the nozzle is connected (figure 12) in such a way that output pressure feedback (from the movement of the Bourdon tube) moves the nozzle in the opposite direction of the flapper. This action completely opens the relay valve for full output pressure or completely closes the relay valve for full exhaust of the output pressure, allowing no in-between throttling.

Figure 12. Direct-Acting, Right-Hand-Mounted Fisher 2500-249 Controller/Transmitter

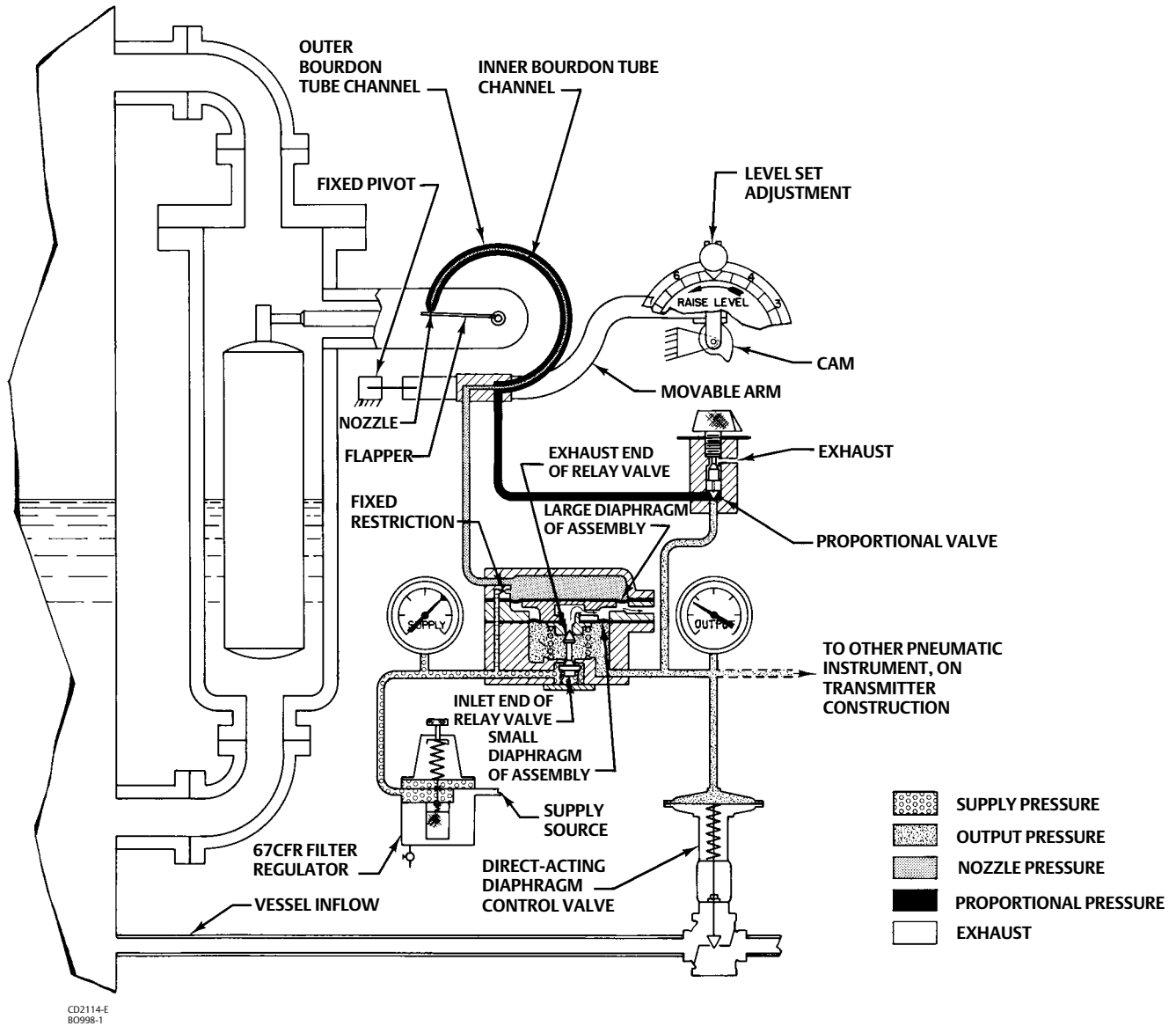

2503 Controller

This construction has the same flapper and sensor arrangement as the 2500 controller, but its Bourdon tube has a three way valve operated by a plunger (see figure 13). Note that the switch point adjustment changes the position of the moveable arm and attached Bourdon tube assembly; this in turn changes the switch point in relationship to the process level. The differential gap of the 2503 either completely opens the relay valve for full output pressure or completely closes the relay valve for full exhaust of the output pressure, allowing no in-between throttling.

For a direct-acting controller, as long as the process variable remains above the switch point, the flapper does not depress the plunger of the Bourdon tube valve. In this condition, the Bourdon tube valve remains closed, providing full

loading pressure to the Bourdon tube. This loading pressure moves the Bourdon tube away from the flapper. Also, in this condition, full loading pressure is on the upper diaphragm of the relay. The loading pressure moves the diaphragm down, closing the exhaust end and opening the inlet end of the relay valve, allowing full output pressure.

When the process level sufficiently decreases, the flapper pushes in the plunger of the Bourdon tube valve enough to release the loading pressure and seal the inner Bourdon tube channel (see figure 13). This decrease in the loading pressure moves the Bourdon tube toward the flapper, producing the snap action. Also, this decrease in loading pressure allows relay spring pressure to move the large diaphragm up, closing the inlet end and opening the exhaust end of the relay valve, allowing full exhaust of the output pressure. This control action continues until a sensor level change moves the flapper away from the plunger, permitting the Bourdon tube valve to close, restoring loading pressure to the pneumatic circuit. Reverse-acting controllers produce the opposite effect.

Figure 13. Direct-Acting Left-Hand-Mounted Fisher 2503 Controller

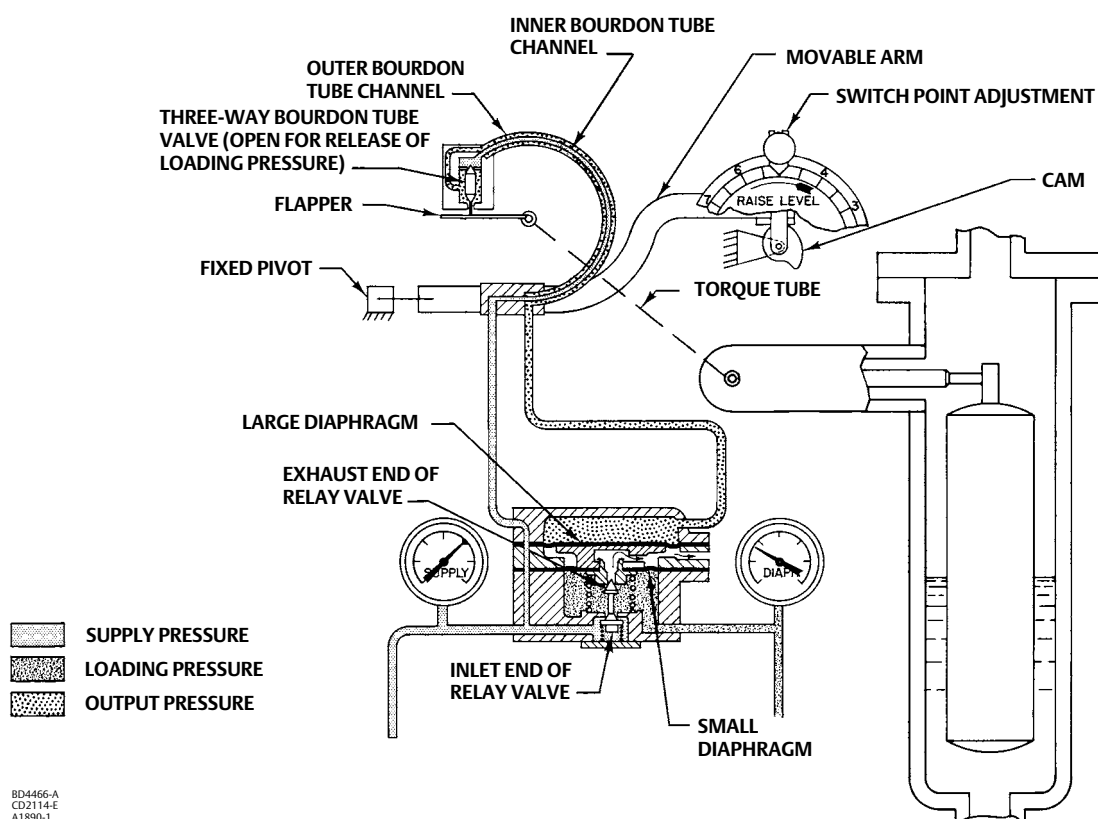

Maintenance

2500 and 2503 controllers/transmitters work in combination with 249 displacers. Refer to figure 16 for key number locations, unless otherwise indicated.

⚠ WARNING

Always wear protective clothing, gloves, and eyewear when performing any maintenance operations to avoid personal injury.

When replacing the sensor assembly, the displacer may retain process fluid or pressure. Personal injury or property damage may occur due to sudden release of the pressure. Contact with hazardous fluid, fire, or explosion can be caused by puncturing, heating, or repairing a displacer that is retaining process pressure or fluid. This danger may not be readily apparent when disassembling the sensor assembly or removing the displacer. Before disassembling the sensor or removing the displacer, observe the more specific warning provided in the sensor instruction manual.

When disconnecting any of the pneumatic connections, natural gas, if used as the supply medium, will seep from the unit and any connected equipment into the surrounding atmosphere. Personal injury or property damage may result from fire or explosion if natural gas is used as the supply medium and preventive measures are not taken.

Preventive measures may include, but are not limited to, one or more of the following:

- remote venting of the unit,
- re-evaluating the hazardous area classification,
- the removal of any ignition sources, and
- ensuring adequate ventilation.

For information on remote venting of this controller refer to page 13.

Check with your process or safety engineer for any additional measures that must be taken to protect against process media.

Troubleshooting

When troubleshooting, open loop conditions must exist unless otherwise stated. When monitoring the process variable, use the most accurate level indicating device available. The output signal measuring device should have corresponding accuracy.

Table 7 lists some common operating faults, their probable causes, and corrective action.

Table 7. Troubleshooting Chart for Fisher 2500 Controller/Transmitters

Fault	Possible Cause	Check	Correction
1. Process wanders or cycles around set point.	1.1 Proportional band or specific gravity adjustment incorrect or improperly tuned control loop.	Ensure the prestartup procedures are completed correctly. Tune control loop.	If stable control cannot be attained and all other elements are functionally correct, examine other possible causes related to the controller/transmitter.
	1.2 Supply pressure varying or incorrect supply pressure setting.	Use input pressure gauge to monitor stability. Make sure regulator IN supply pressure is within limits.	Apply correct supply pressure. Use one regulator per instrument.
	1.3 Sensor not plumb and is in contact with sidewall or leak in displacer.	Check cage vessel and stillwell installation, or for leaking displacer.	Make sure the displacer and displacer rod hangs freely. Make sure linkage is tight. Replace displacer if leaking.
	1.4 Relay malfunction.	Check for relay malfunction by using the testing relay deadband procedure.	Depress plunger to clean out the fixed restriction. Replace relay using the procedure in the Maintenance section.

-continued-

Table 7. Troubleshooting Chart for Fisher 2500 Controller/Transmitters (continued)

Fault	Possible Cause	Check	Correction
2. Controller/transmitter controlling off set point or switching point.	2.1 Supply pressure not set correctly.	Make sure regulator supply pressure is set correctly. Make sure regulator IN supply pressure is within limits.	Reset the supply regulator pressure. If the condition occurs again, rebuild or replace regulator. Provide a regulator input pressure within regulator limits.
	2.2 Leak in the controller/transmitter loop.	Use soap and water to check for internal and external leaks.	Replace or repair leaking parts as necessary.
	2.3 Leaking displacer.	Ensure the displacer is not filling with process fluid.	Refer to sensor maintenance procedures in the appropriate sensor instruction manual.
	2.4 Flapper adjustment.	Ensure the flapper is not loose on the torque tube shaft and is centered on the nozzle.	Replace or tighten flapper assembly as necessary and/or center flapper on nozzle.
	2.5 Process variable changed.	Ensure the process variable has not changed from original calibration settings, or displacer not designed for specific gravity of process.	Change process variable back to original specification or recalibrate. If necessary, provide replacement displacer of correct size and recalibrate.
3. Controller/transmitter cannot attain full output range.	3.1 Supply pressure not set correctly.	Make sure supply pressure is set correctly. Make sure regulator IN supply pressure is within limits.	Reset the regulator pressure. If problem reoccurs, replace or rebuild the regulator. Ensure regulator IN supply pressure is within limits at all operating levels.
	3.2 Flapper adjustment.	Ensure the flapper is not loose on the torque tube shaft and is centered on the nozzle.	Replace or tighten flapper assembly as necessary and/or center flapper on nozzle.
	3.3 Process variable changed.	Ensure the process variable has not changed from original calibration settings, or from displacers designed specific gravity.	Change process variable back to original specification or recalibrate. If necessary, provide replacement displacer of correct size and recalibrate.
	3.4 Relay malfunction	Check for relay malfunction by using the testing relay deadband procedure.	Depress plunger to clean out the fixed restriction. Replace relay using the procedure in the Maintenance section.
	3.5 Leak in the controller/transmitter loop.	Use soap and water to check for internal and external leaks.	Replace or repair leaking parts as necessary.
4. Controller/transmitter remains at full or zero output pressure.	4.1 Supply or output pressure gauge malfunction.	Ensure the pressure gauges are registering correctly.	Replace pressure gauges. Use corrective action given in section 3 of this table.
	4.2 Flapper adjustment.	Ensure the flapper is not loose on the torque tube shaft and is centered on the nozzle.	Replace or tighten flapper assembly as necessary and/or center flapper on nozzle.

Removing Controller/Transmitter from Sensor

⚠ WARNING

To avoid injury in the following steps, turn off the supply pressure and carefully release any pressure trapped in the controller/transmitter before breaking any pressure connection. Provide a bypass for the control device if continuous operation is required during maintenance.

1. Disconnect the supply and output pressure tubing from the controller or transmitter. For a controller/transmitter with an indicator, remove the pointer assembly by referring to the Replacing the Bourdon Tube section.
2. Loosen the top hex clamp nut (key 40, figure 16) and remove the flapper base (key 30, figure 16) from the torque tube rotary shaft.

CAUTION

If the hex clamp nut has not been loosened or the pointer removed according to step 2, attempting to remove the controller/transmitter from the sensor may bend the flapper or rotary shaft. Be careful that the back of the controller/transmitter case or the heat insulator does not drop down and bend the rotary shaft or shaft extension.

- Remove any insulating tape from the joint between the controller/transmitter case and the torque tube arm. Remove the four cap screws (key 39, figure 14) that hold the controller/transmitter or heat insulator to the torque tube arm. Pull the case straight out from the torque tube arm, easing it over the shaft coupling (key 36, figure 14) if one is installed.

Figure 14. Heat Insulator for Fisher 249 Sensor

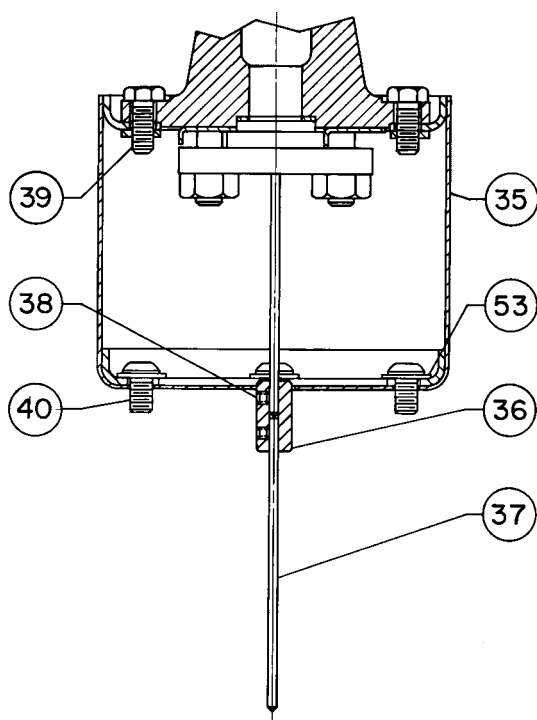

20A7423-C

- If the controller/transmitter has a heat insulator, remove the four button head cap screws and washers (keys 40 and 53, figure 14) and remove the insulator assembly.

Changing Mounting Methods

⚠ WARNING

To avoid personal injury from contact with the process fluid, lower the vessel fluid level below the torque-tube arm before proceeding. For closed vessels, release any pressure that may be above the fluid. Also, be careful to avoid overloading a thin-wall torque tube with an overweight displacer.

Refer to figure 16 for key number locations.

1. Remove the controller/transmitter as described previously.
2. A controller/transmitter is attached to the sensor in one of the mounting positions shown in figure 4. Right-hand mounting is with the controller/transmitter case (key 1) to the right of the displacer (FLOAT), as you look at the front of the case, left-hand mounting is with the case to the left of the displacer. For a 249 sensor, remove the torque tube arm from the sensor or vessel and reinstall the torque tube arm in the opposite position according to the appropriate instruction manual. Note that the term FLOAT is marked on the RAISE LEVEL dial and the indicator plate, if one is used.
3. Check the desired control action. If the control action is not correct, refer to the changing action procedures to change it. Mount the Bourdon tube in one of the positions shown in figure 15.
4. The arrow on the RAISE LEVEL dial under the word FLOAT should point toward the displacer. If not, remove the dial from the controller, turn it over, and install it in the correct position.
5. For a controller/transmitter with an indicator assembly, the arrow near the word FLOAT on the indicator plate should point toward the displacer. If it does not, remove the two screws (key 41, see detail of indicator assembly in figure 16), turn the front plate (key 54) to the side with the FLOAT arrow pointing toward the displacer, and secure the plate with the screws.
6. Install the controller/transmitter according to the next section.

Installing Controller/Transmitter on Sensor

Note

If the installation is in a location that is not readily accessible and shop calibration is required, remove the torque tube arm from the cage or vessel before installing the controller or transmitter to the sensor. Install the controller/transmitter on the torque tube arm in the shop; then calibrate and return the controller/transmitter with the torque tube arm assembly attached for installation. Perform step 1 only if adding a heat insulator to a unit that does not have one. Key numbers in this step are shown in figure 14.

1. To install the heat insulator, secure the shaft extension (key 37) to the torque tube assembly rotary shaft with the shaft coupling (key 36). Tighten both set screws (key 38), with the coupling centered as shown in figure 14. Then mount the insulator assembly (key 35) on the controller/transmitter case with four button head cap screws and washers (keys 40 and 53). Tighten the screws.

CAUTION

In the following step, avoid bending the rotary shaft of the torque tube assembly. Bending or side loading of this shaft could cause erroneous readings. Additionally, make sure the ball bearing assembly (key 12, figure 16) is removed from the case (key 1, figure 16) to provide clearance when installing the case on the sensor.

2. Remove the bearing assembly (key 12, figure 16) from the case (key 1, figure 16).
3. Carefully slide the controller/transmitter case straight in. Secure the case on the torque arm or insulator with the four cap screws (key 39).

Note

If a heat insulator is used, do not insulate its exterior.

4. Slide the bearing assembly (key 12, figure 16) onto the shaft or shaft extension of the insulator, and install the bearing assembly (key 12, figure 16) into the case (key 1, figure 16).
5. Install the flapper base (key 30, figure 16) on the torque tube rotary shaft, making sure the flapper is centered over the nozzle or Bourdon tube valve. Secure the base with the hex nut (key 40, figure 16). For a controller/transmitter with an indicator assembly, install the pointer assembly according to the Replacing the Bourdon Tube section.
6. Connect the supply and output pressure tubing and perform the calibration procedure.

Replacing the Bourdon Tube

Refer to figure 16 for key number locations.

1. Disconnect the tubing (key 10 for 2503 and key 11 for 2500) from the Bourdon tube base. For a controller/transmitter with indicator assembly, loosen the side hex clamp nut (key 40) and remove the pointer assembly (key 51) from the torque tube rotary shaft.
2. Remove the mounting screws (key 45) and Bourdon tube assembly (key 16).
3. Inspect the Bourdon tube. Replace it if necessary, using a tube with a black color code for a 0.2 to 1 bar or 0 to 1.4 bar (3 to 15 psig or 0 to 20 psig) range. Use a tube with a red color code for a 0.4 to 2 bar or 0 to 2.4 bar (6 to 30 psig or 0 to 35 psig) range. The range is stamped at the Bourdon tube base.
4. Mount the Bourdon tube on the level set arm (key 28). Secure it with the mounting screws, using the proper orientation as shown in figure 15. Connect the tubing to the tube base, with tubing from the R connection on the relay (key 34) going to the marked base connection. The other tubing goes to the unmarked base connection. With an indicator assembly, install the pointer assembly on the rotary shaft and tighten the hex nut.
5. Perform the calibration procedure.

Changing Action

Note

The following procedure is necessary to restore previous action if the mounting method has been changed. Figure 16 shows key numbers.

1. Reposition the Bourdon tube (and indicator assembly, if used) according to steps 1 through 4 of the Replacing the Bourdon Tube section.
2. Loosen the hex nut (key 40) and remove the flapper base (key 30) from the torque tube rotary shaft. Turn the flapper base over and install it on the rotary shaft, using the proper orientation as shown in figure 15 and making sure the flapper is centered over the nozzle or Bourdon tube valve.
3. Perform the calibration procedure.

Figure 15. Bourdon Tube-Flapper Arrangements for Various Actions and Mountings

CONSTRUCTION	DIRECT ACTING—RIGHT HAND MOUNTING REVERSE ACTING—LEFT HAND MOUNTING	REVERSE ACTING—RIGHT HAND MOUNTING DIRECT ACTING—LEFT HAND MOUNTING
2500 OR 2500T (INCLUDING C VERSIONS)		
2500S (INCLUDING C VERSIONS)		
2503		

AC9554
AR8148
BO996-1

Relay Deadband Testing (2500 Controller or 2500T Transmitter Only)

1. Replace the appropriate (proportional or specific gravity) adjustment assembly with the 1/8 NPT pipe plug according to the Replacing the Proportional Valve section.
2. Turn on the supply pressure and set it to 1.4 to 2.4 bar (20 or 35 psig), depending on the controller/transmitter operating range.
3. By changing the process variable and adjusting the RAISE LEVEL or ZERO ADJUSTMENT control, set the output pressure to 1.0 or 2.0 bar (15 or 30 psig). While monitoring the output pressure, slowly change the process variable until the output pressure just changes, and record the value of the process variable at the detection point.
4. Change the process variable in the opposite direction until the output pressure just changes and again record the value of the process variable. If the difference between the two recorded values (the deadband) is more than 0.2% of the maximum displacer length, the relay must be replaced or repaired according to the Changing Relay section.
5. Turn off the supply pressure, remove the pipe plug, and install the appropriate adjustment assembly.

Replacing the Proportional Valve

Note

The following procedure, to convert to or from the pipe plug or the desired adjustment assembly, can be used for any type number covered in this manual.

1. Remove the tubing (key 10) from the proportional band valve assembly.
2. Unscrew the base of the PROPORTIONAL BAND or SPECIFIC GRAVITY adjustment assembly (key 36 or 90, figure 16), or the 1/8 NPT pipe plug (key 73, not shown), from the relay base (key 23, figure 16).
3. Install the pipe plug or the desired adjustment assembly into the relay base.
4. Replace the tubing (key 10) to the proportional band valve assembly.

Changing Relay

The relay may be removed for cleaning or replacement.

Removal

1. For a controller or transmitter with indicator assembly, loosen the two lower relay screws (key 96) and slide out the indicator base plate (key 53).
2. Disconnect the tubing (key 10 or 11) from the relay.
3. Remove both mounting screws, relay, and relay gasket (keys 43, 34, and 22).

Replacement

1. Install a new gasket (key 22), the replacement relay (key 34), and secure with two mounting screws (key 43). On a controller or transmitter with an indicator assembly, slide the base plate under the two lower screws of the relay case, align the plate so the pointer will read properly, and tighten the screws.
2. Connect the tubing (key 10 or 11) to the relay.
3. Test the relay deadband, according to the Relay Deadband Testing procedure in this section.
4. If the deadband is within tolerance, go to the Calibration section.

Parts Ordering

Whenever corresponding with your [Emerson sales office](#) or Local Business Partner about this equipment, use the controller/transmitter type number and the serial number. The serial number is found on the nameplate (key 215, figure 16).

⚠ WARNING

Use only genuine Fisher replacement parts. Components that are not supplied by Emerson Automation Solutions should not, under any circumstances, be used in any Fisher instrument. Use of components not supplied by Emerson Automation Solutions may void your warranty, might adversely affect the performance of the instrument, and could cause personal injury and property damage.

Parts List

Description	Part Number
Controller Parts Kits	
2500 Controller Repair Kits Contains keys 12, 15, 21, 24, 38, and the flapper assembly Standard temperature High temperature	R2500X00L32 R2500X00H32
2503 Controller Repair Kit Standard temperature only The kit contains keys 12, 21, 22, 24, 38, and the flapper assembly.	R2503X00022
Relay Replacement Kit Contains keys 22, 43, and the relay assembly Standard temperature High temperature	RRELAYX0L22 RRELAYX0H22
Heat Insulator Retrofit Kit Contains the heat insulator parts shown in figure 14 and listed under Heat Insulator in this parts list	R2500XH0012
2500 Controller Cover Gasket Kit Contains qty. 5 cover gaskets, key 21	R2500CVR012

Common Controller/Transmitter Parts (figure 16)

Note

Contact your [Emerson sales office](#) or Local Business Partner for Part Ordering information.

Key Description

- 1 Case back
- 2 Case cover, aluminum
- 3 Door handle, pl steel

Key	Description
4	Door handle shaft (not shown), brass
5	Machine screw, steel
6	Spring washer, stainless steel
7	Door hook, pl steel
8	Stop nut, pl steel
9	Drive-lock pin, (2 req'd)
10	Tubing assembly, stainless steel For all 2500 controllers/transmitters except 2503 For 2503 only
11	Relay tubing, stainless steel
12*	Ball bearing assembly, Brass, pl
13	Retaining ring, pl steel (2 req'd)
14*	Gauge glass (2 req'd)
15*	Gauge glass gasket, chloroprene (2 req'd)
16*	Bourdon tube assembly, Brass 2500 and 2500T 3 to 15 psig 6 to 30 psig 2500S 0 to 20 psig 0 to 35 psig 2503 0 to 20 psig 0 to 35 psig Stainless steel 2500 and 2500T 3 to 15 psig 6 to 30 psig
19*	Triple scale gauge (2 req'd) Brass 0 to 30 psig/0 to 0.2 MPa/0 to 2 bar 0 to 60 psig/0 to 0.4 MPa/0 to 4 bar Stainless steel 0 to 30 psig/0 to 0.2 MPa/0 to 2 bar 0 to 60 psig/0 to 0.4 MPa/0 to 4 bar
19*	Dual scale gauge (2 req'd) Brass 0 to 30 psig / 0 to 2 kg/cm ² 0 to 60 psig / 0 to 4 kg/cm ² Stainless steel 0 to 30 psig / 0 to 2 kg/cm ²

Figure 16. Fisher 2500 Controller / Transmitter Constructions

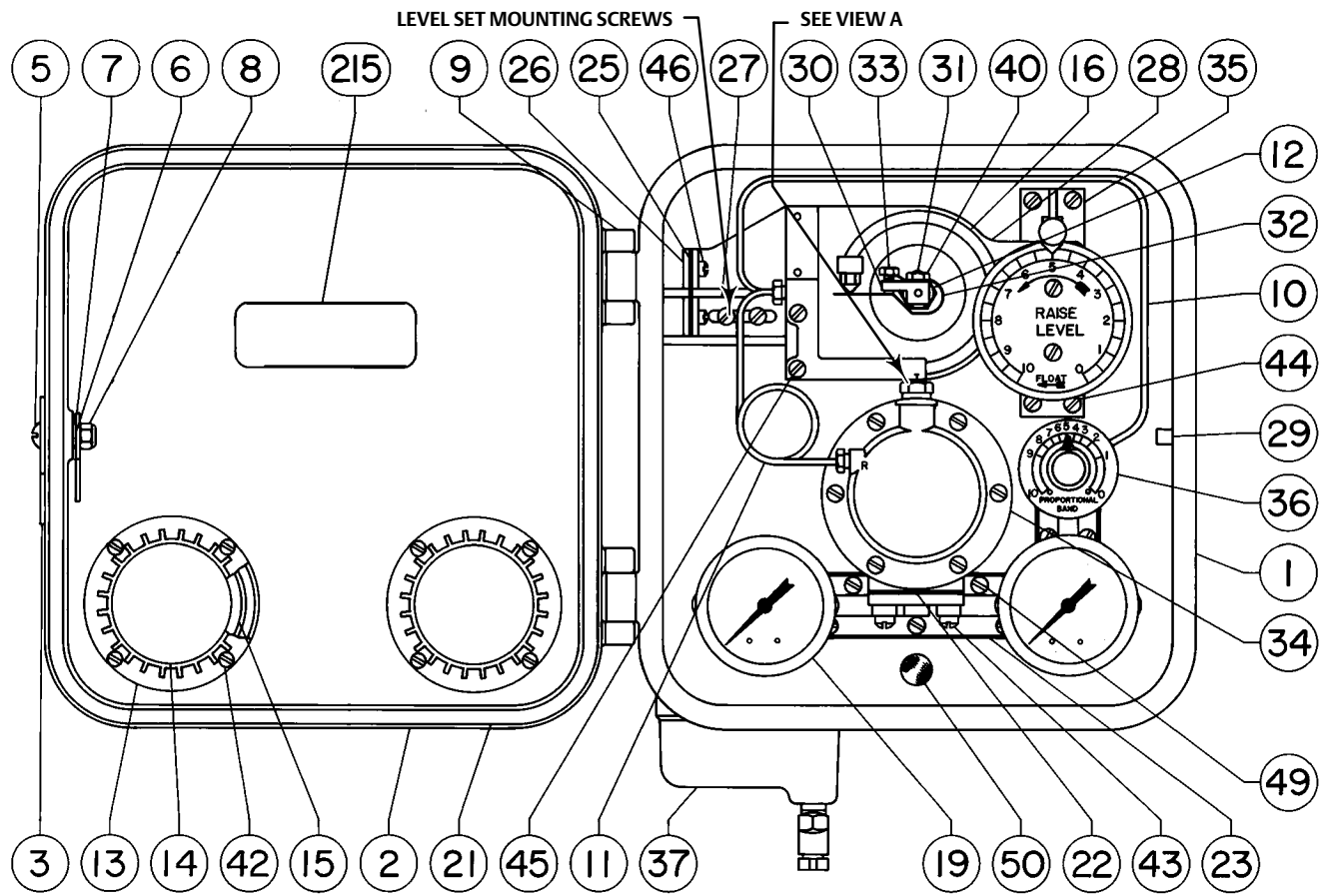

TYPICAL CONTROLLER

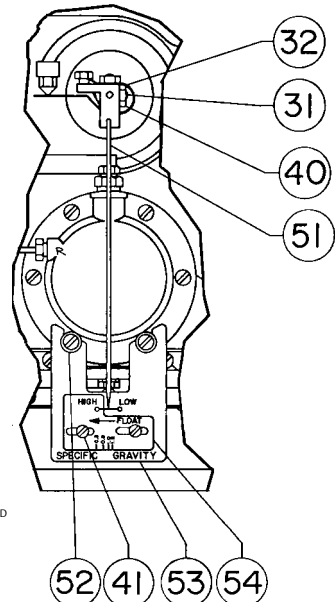
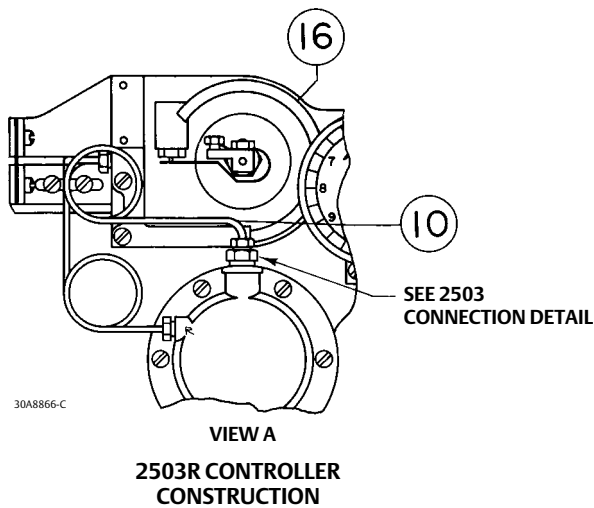

DETAIL OF INDICATOR ASSEMBLY ON C VERSIONS

NOTE:
PARTS NOT SHOWN 4, 24, 38, 39, 47, AND 48.

Key	Description	Key	Description
21*	Cover gasket, chloroprene	40	Hex nut, pl steel (2 req'd for C versions, 1 req'd for all others)
22*	Relay gasket Standard temperature, chloroprene High temperature, silicon	41	Screw, pl steel (2 req'd for C versions only)
23	Relay base	42	Machine screw, pl steel (8 req'd)
24*	Relay base gasket (not shown) Standard temperature, chloroprene High temperature, silicon	43	Machine screw, pl steel (2 req'd)
25	Flexure strip, stainless steel,	44	Machine screw, pl steel (6 req'd)
26	Flexure strip nut, pl steel (2 req'd)	45	Machine Screw, pl steel (2 req'd)
27	Flexure strip base, pl steel	46	Machine Screw, pl steel (4 req'd)
28	Level set arm, pl steel	47	Spring (not shown), stainless steel
29	Drivelok pin, pl steel	48	Cap screw, pl steel (4 req'd)
30	Flapper base, brass, pl	49	Machine screw, pl steel (13 req'd)
31	Shaft clamp screw, SST (2 req'd for C version only, 1 req'd for all others)	50	Screen, N04400
32	Flapper, stainless steel	51	Pointer assembly (C versions only), Stainless steel/brass, pl
33	Alignment screw, brass, pl	52	Washer (C versions only), steel (2 req'd)
34	Relay assembly For all 2500 controllers/transmitters except 2503 Standard temperature High temperature Corrosive service 2503 only Standard temperature High temperature	53	Base plate (C versions only), aluminum
35	Level adjustment assembly (controllers only)	54	Front plate (C versions only), aluminum
35	Zero adjustment assembly (transmitters only)	73	Pipe plug (2503 only), brass (not shown)
36	Proportional band adjustment assembly (except transmitters and 2503 controllers, see key 90) Standard and high temperature Corrosive service	90	Specific gravity adjustment assembly Standard and high temperature Corrosive service
37	67CFR regulator	215	Nameplate
38A*	Filter gasket (not shown) Standard temperature, chloroprene High temperature, silicon		
38B	Spacer, aluminum (not shown)		
38C*	O-ring (not shown) Standard temperature, nitrile High temperature, fluoroelastomer		
39	Cap screw (not shown), pl steel (2 req'd)		

Heat Insulator (figure 14)

Note

All Heat Insulator parts are included in the Heat Insulator Parts Kit.

35	Heat Insulator Assembly, stainless steel
36	Shaft Coupling, stainless steel
37	Shaft extension, N05500
38	Set screw, stainless steel (2 req'd)
39	Cap screw, pl steel (4 req'd)
40	Cap screw, pl steel (4 req'd)
53	Washer, carbon steel, pl (4 req'd)

*Recommended spare parts

Neither Emerson, Emerson Automation Solutions, nor any of their affiliated entities assumes responsibility for the selection, use or maintenance of any product. Responsibility for proper selection, use, and maintenance of any product remains solely with the purchaser and end user.

Fisher is a mark owned by one of the companies in the Emerson Automation Solutions business unit of Emerson Electric Co. Emerson Automation Solutions, Emerson, and the Emerson logo are trademarks and service marks of Emerson Electric Co. All other marks are the property of their respective owners.

The contents of this publication are presented for informational purposes only, and while every effort has been made to ensure their accuracy, they are not to be construed as warranties or guarantees, express or implied, regarding the products or services described herein or their use or applicability. All sales are governed by our terms and conditions, which are available upon request. We reserve the right to modify or improve the designs or specifications of such products at any time without notice.

Emerson Automation Solutions
Marshalltown, Iowa 50158 USA
Sorocaba, 18087 Brazil
Cernay, 68700 France
Dubai, United Arab Emirates
Singapore 128461 Singapore

www.Fisher.com

